

Dellmecco®

INSTRUCTION MANUAL

Air Operated Double Diaphragm Pumps

Plastic Series

Ver. 1.31

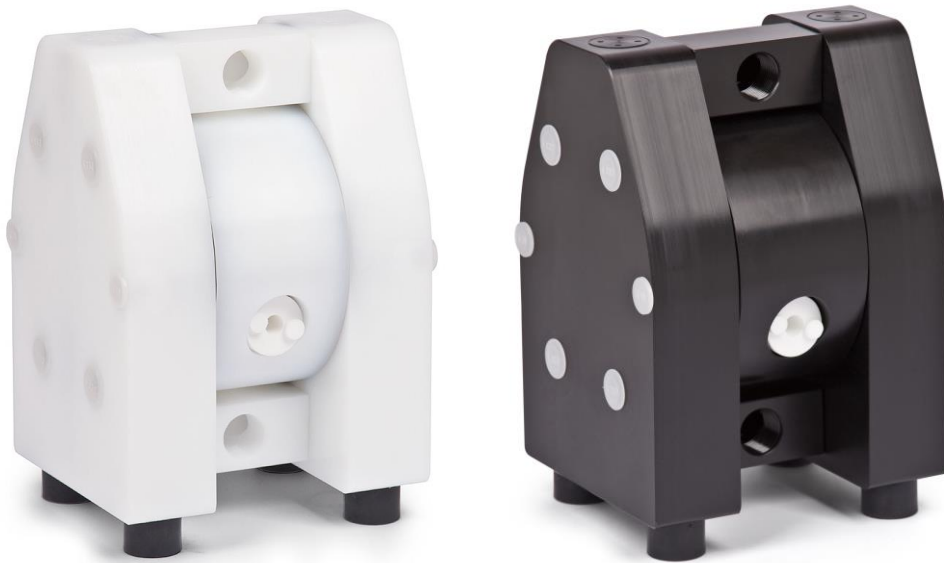

Models:

DM 08/10 P., T. and ATEX: DM 08/10 R., Z..

DM 10/25 P., T. and ATEX: DM 10/25 R., Z..

DM 15/55 P., T. and ATEX: DM 15/55 R., Z..

DM 25/125 P., T. and ATEX: DM 25/125 R., Z..

DM 40/315 P., T. and ATEX: DM 40/315 R., Z..

DM 50/565 P., T. and ATEX: DM 50/565 R., Z..

DM 80/850 P., T. and ATEX: DM 80/850 R., Z..



Model:

Serial no.:

DECLARATION OF CONFORMITY

Directive 2006/42/EC, Annex 2A

Company: **DELLMECO Krzysztof Ziemann**

Address: **Swierkowa 2
83-330 Glinicz
POLAND**

declares under our sole responsibility, that the product:

Product name: **Air Operated Double Diaphragm Pumps**

Models: **DM - series**

Referred to in this declaration conforms with the:

- Directive 2006/42/EC

Date: **July 1st 2014**



**K. Ziemann
Managing Director**

Table of contents

1. Introduction	5
2. For safe operation	5
3. Warnings and cautions	5
4. Operating caution	5
5. Names of parts and materials	7
5.1. DM 08/10 P., DM 08/10 T., DM 10/25 P., DM 10/25 T.. – exploded view	7
5.2. DM 08/10 R., DM 08/10 Z., DM 10/25 R., DM 10/25 Z.. (ATEX) – exploded view	10
5.3. DM 15/55 P., DM 15/55 T., DM 25/125 P., DM 25/125 T.. – exploded view	13
5.4. DM 15/55 R., DM 15/55 Z., DM 25/125 R., DM 25/125 Z.. (ATEX) – exploded view	16
5.5. DM 40/315 P., DM 40/315 T., DM 50/565 P., DM 50/565 T.. – exploded view	19
5.6. DM 40/315 R., DM 40/315 Z., DM 50/565 R., DM 50/565 Z.. (ATEX) – exploded view	22
5.7. DM 80/850 P., DM 80-850 T.. – exploded view	25
5.8. DM 80/850 R., DM 80-850 Z.. (ATEX) – exploded view	28
6. Assembly	31
7. Installation	31
7.1. Installing the pump	31
7.2. Connecting the ground wire	33
8. Connection	33
8.1. Connecting fluid piping	33
8.2. Connecting air piping	34
9. Operation	35
9.1. Method of operation	35
9.2. Flow adjustment	35
9.3. Shutdown	36
10. Method of cleaning	36
11. Daily check	37
12. Possible problems	37
13. Pump storage	39
14. Returning the product for servicing	39
14. Main body specification	41
14.1. Main specification	41
14.2. Appearance and dimensions	41
14.3. Technical Data	42
14.4. Pump code	42
14.5. Performance curves	43
15. Dellmeco Active Pulsation Dampeners for Plastic Pumps	44
15.1. Main specification	44
15.2. Appearance and dimensions (Pulsation Dampener only)	48
15.3. Appearance and dimensions (Plastic Pump with Pulsation Dampener assembled)	49
15.4. Discharge port for PD (Pulsation Dampener)	49
16. Optional Equipment	50
16.1. Barrier Chamber System (Option codes: BC1, BC2, BC3)	50
16.2. Stroke Counting (Option codes: SC1, SC2, SC3, SC5, SC6)	55
16.3. Diaphragm Monitoring (Option codes: DM1, DM2)	58
16.4. Flange Connections (Option codes: F1, F2, F3, F1.1, F2.1, F3.1, F4, F7, F8, F9, F4-I, F7-I, F8-I, F9-I, F4.1, F7.1, F8.1, F9.1, F4.1-I, F7.1-I, F8.1-I, F9.1-I)	60
16.5. Back Flushing System (Option codes: BF1, BF2, BF4, BF5)	62
16.6. Compressed air preparation set (Option codes: AF1, AF2)	63
16.7. Drum Pump (Option codes: D1, D2)	64
16.8. High Pressure System (Option codes: HPM, HPS)	65
16.9. Pump with solenoid valve (Option code MV)	70

16.10 Pump for transferring powders (Option code P)	71
16.11. Sleeve with Split Connections (option code S)	72
16.12. Inlet/outlet stainless steel connections (AISI 316L, option code SSC)	73
16.13. Trolley for pumps (Option code T)	74
16.14. Inlet/outlet connections with BSPT thread (Option code BSPT)	75
16.15. Inlet/outlet connections with NPT thread (Option code NPT)	75
16.16. Air valve (thread-mounted) execution material option and spare parts kit set (AVD)	75
16.17. Actual version of the exhaust muffler (comparison with the previous execution)	78
16.18. A change in the manner of assembling/disassembling way of valve seats (available only for Plastic Series Pump models: from DM 10/25 to DM 50/565)	79
16.19. Central housing with Enhanced Air Valve (EAV Option)	81
16.20. ATEX Certificate	82
17. Differences in construction of the air valve and special keys list	83
18. Limited warranty	86

1. Introduction

This pump is a positive-displacement pump that transfers fluids by means of diaphragms movement operated by compressed air. The casing in contact with the fluid is made of PE (polyethylene), PE conductive (PE for ATEX), PTFE (polytetrafluoroethylene) and PTFE conductive (PTFE for ATEX).

2. For safe operation

This document contains information indispensable for maintaining safe and efficient operation of this product. Read this document carefully before using the pump, particularly the "Warnings and cautions". Get familiar with all operating procedures. This document must be kept handy for future reference.

3. Warnings and cautions

The meanings of warning and caution symbols are given below. Be sure to remember their meanings.



WARNING:

ignoring the warning and operating the product in an improper manner can result in danger of serious bodily injury or death.



CAUTION:

ignoring the warning and operating the product in an improper manner can result in danger of personal injury or property damage.



This symbol means a "DON'T", and will be followed by an explanation on what you must not do.



This symbol means a "DO", and will be followed by an explanation on what you must do in a specified situation.

4. Operating caution

Before using this product



WARNING



To drive the pump you must use one of the following compressed gases (called in this document "compressed air"):

- Compressed air supplied from air compressor
- Nitrogen (N₂) gas

Use of compressed air other than the above may cause air pollution, damage to the pump, or even an explosion.



The maximum permissible pressure for the compressed air, and the fluid pumped by one of its pumps is 7 bar g. Should the above applicable maximum permissible pressure be exceeded, the following results may follow: damage to the casing, or even a severe, possibly fatal accident.

In some Plastic Series Pumps executions, specified by manufacturer, the maximum pressure can reach 12÷13 bar g.



In case a diaphragm gets damaged, fluid will gush out together with air through the exhaust port. Provide protective measures in consideration of possible leakage of fluid.

When using the pump with suction/discharge hoses, tank etc. for pumping, make sure to use a model with appropriate corrosion resistance for the fluid to be pumped.



WARNING

- ! When installing this product, be sure to connect a ground wire from the specified position of this product. Otherwise friction between parts and abrasion caused by the flow of some fluids inside the casing may generate static electricity. Depending on the type of fluid being pumped and the installation environment (such as gases in the air and type of surrounding mixtures), static electricity could cause fire or electric shock.
- ! Some fluid may remain inside the pump and inside the connected piping after shutting down the pump, or if the pump is left unused for a prolonged period. Therefore, be sure to purge the system of fluid and clean the pump before prolonged disuse. The fluid remaining in the connected piping as well as the pump itself may expand because of freezing or heat which may cause damage to the pump or/and piping and lead to leakage of the fluid.
- Ø Use only genuine DELLMECO parts when replacing component parts of this product.
- ! Torque of all tightening parts must be checked before running the pump. Designated torques are mentioned in maintenance manual.
- ! In case of pumping a hazardous fluid (hot, flammable, strong acid, etc.) with this pump, protective measures (install a pit, a protection box, sensors, etc.) must be provided in consideration of possible leakage of fluid. Warning signs must be displayed at necessary places. Leakage of fluid may cause fire or accident.
- ! Before using this pump, get fully familiar with the precautions regarding the fluid to be pumped, and verify the corrosion resistance of the parts that will come into contact with the fluid. NEVER use the pump with any fluid against which it does not have sufficient corrosion resistance or with a fluid that poses a risk of explosion. If you are unable to verify the corrosion resistance, contact your dealer. Using this product with any fluid against which the parts in contact with the fluid do not have sufficient corrosion resistance may result in damaging the product or leakage of fluid.



CAUTION

- ! The running pump may generate loud operating noise. Its level will vary depending upon the conditions of use (fluid pumped, supply air pressure and discharge pressure)
- ! To drive this product, supply air with minimum moisture content and without any oil and/or dirt.
- ! If a diaphragm of this pump is damaged, supply air may mix with the fluid or the fluid may flow into the central housing. DO NOT OPERATE THE PUMP if air supply is inadequate or contaminated.
- Ø While operating this product, do NOT put your hand on the inlet port.

5. Names of parts and materials

5.1. DM 08/10 P., DM 08/10 T., DM 10/25 P., DM 10/25 T.. – exploded view

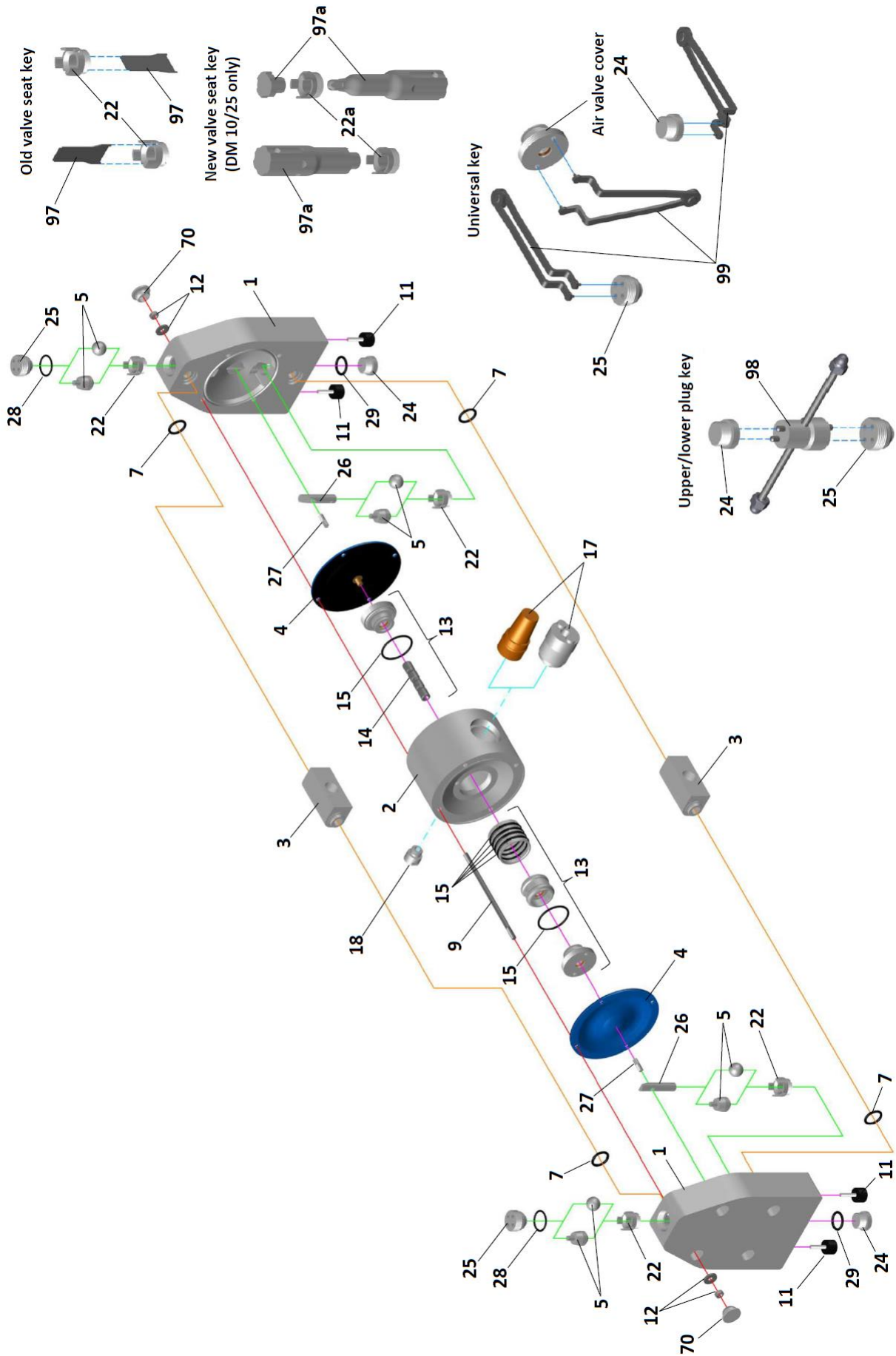

Spare parts list for DM 08/10 P., T.. and DM 10/25 P., T.. Plastic Series Pumps

Item	Part name	Quantity	Material	Pump size and material execution (P-PE, T-PTFE)			
				DM 08/10 P..	DM 08/10 T..	DM 10/25 P..	DM 10/25 T..
1.	Pump housing	2	PE	2 08 01 20		2 10 01 20	
			PTFE		2 08 01 23		2 10 01 23
2.**	Central housing	1	PE	1 08 10 20		1 10 10 20	
3.	Suction/discharge port	2	PE	2 08 30 20		2 10 30 20	
			PTFE		2 08 30 23		2 10 30 23
4.	Diaphragm	2	EPDM			1 10 50 08	
			NBR			1 10 50 10	
			TFM(PTFE)	1 08 50 05		1 10 50 05	
			TFM(PTFE)-PFA	1 08 50 00		1 10 50 00	
5.	Cylinder valves	4	PTFE	2 08 56 23		2 10 56 23	
	Ball valves	4	AISI 316	1 08 60 52		1 10 60 52	
			EPDM		1 10 60 08		
			NBR		1 10 60 10		
			PTFE	1 08 60 23		1 10 60 23	
			Ceramic		1 10 60 90		
7.*	In-/outlet sealing	4	EPDM			2 10 70 08	
			FEP/Silicone core	2 08 70 03		2 10 70 03	
			FEP/FKM core	2 08 70 04		2 10 70 04	
			FKM		2 10 70 09		
			NBR		2 10 70 10		
9.	Housing bolt	4	AISI 304	2 08 042 50		2 10 042 50	
11.	Shock absorber	4	NR/St37	1 08 69 06		1 10 69 06	
12.	Nut with washer set	8	AISI 304	2 08 045 50		2 10 045 50	
13.**	Air valve, complete (thread mount)	1	PET-NBR		1 08 020 31		
			PET-FKM		1 08 020 32		
14. ¹⁾	Air valve and diaphragm shaft	1	AISI 304		1 08 24 50		
15. ¹⁾	Air valve O-ring, external	6	NBR		1 08 080 10		
			FKM		1 08 080 09		
17.**	Exhaust muffler, old version	1	PE porous		1 08 99 35		
			Bronze (sintered)		1 08 99 86		
	Exhaust muffler, actual version	1	PE porous		1 08 499 35		
			Bronze (sintered)		1 08 499 86		
18.**	Air adapter	1	PP		1 08 46 28		
22.	Valve seat, old type (flat assembling key)	4	PE	2 08 54 20		2 10 54 20	
			PTFE		2 08 54 23		2 10 54 23
22a.	Valve seat, new type (new assembling key)	4	PE			2 10 654 20	
			PTFE				2 10 654 23
24.	Plug lower	2	PE	2 08 59 20		2 10 59 20	
			PTFE		2 08 59 23		2 10 59 23
25.	Plug upper	2	PE	2 08 055 20		2 10 055 20	
			PTFE		2 08 055 23		2 10 055 23
26.	Valve stopper	2	PE	2 08 39 20		2 10 39 20	
			PTFE		2 08 39 23		2 10 39 23
27.	Bolt	2	PE	2 08 38 20		2 10 38 20	
			PTFE		2 08 38 23		2 10 38 23
28.***	Plug upper sealing	2	EPDM			2 10 78 08	
			FEP/Silicone core	2 08 78 03		2 10 78 03	
			FEP/FKM core	2 08 78 04		2 10 78 04	
			FKM		2 10 78 09		
			NBR		2 10 78 10		
29.***	Plug lower sealing	2	EPDM			2 10 478 08	
			FEP/Silicone core	2 08 78 03		2 10 478 03	
			FEP/FKM core	2 08 78 04		2 10 478 04	
			FKM		2 10 478 09		
			NBR		2 10 478 10		
35.	Central housing complete	1	Diverse	1 08 11 20		1 10 11 20	
70.	Pump housing plug set	1	PE	2 08 058 20		2 10 058 20	
97.****	Valve seat key, flat (for 22.)	1	Structural steel	2 08 254 47		2 10 254 47	
97a.****	Valve seat key cpl (for 22a.)	1	Diverse		2 10 254C 00		
98.****	Upper/lower plug key	1	Diverse	1 08 158 00		1 10 158 00	
99.****	Universal key	1	Structural steel		1 10 58 00		

- * - in-/outlet standard sealing O-rings material: EPDM for EPDM diaphragms, NBR for NBR diaphragms, FEP/Silicone (FEP encapsulated Silicone core) for TFM(PTFE) and TFM(PTFE)-PFA diaphragms;
- ** - parts included in Item 35 „Central housing complete“;
- *** - plug upper/lower standard sealing O-rings material: EPDM for EPDM diaphragms, NBR for NBR diaphragms, FEP/Silicone (FEP encapsulated Silicone core) for TFM(PTFE) and TFM(PTFE)-PFA diaphragms;
- **** - available on request (not delivered with the pump nor with spare part kit sets).
- ¹⁾ - included in Item 13 „Air valve, complete“, but also can be ordered separately.

List of parts for spare part kits SET 1 and SET 2 in Plastic Series Pumps DM 08/10 and DM 10/25 P.. (T..)

Spare part kit set type	Item	Quantity	Part description	Pump size								
				08/10				10/25				
				Material execution ^{A)}								
				PTT (TTT)	PTF (TTF)	PTS (TTS)	PEE (TEE)	PNN (TNN)	PTT (TTT)	PTF (TTF)	PTS (TTS)	
				Part number								
SET 1 (wet side)	4.	2	Diaphragm	1 08 50 05		1 10 50 08	1 10 50 10	1 10 50 05				
	5.	4	Valve ball	1 08 60 23		1 08 60 52	1 10 60 08	1 10 60 10	1 10 60 23		1 10 60 52	
			Cylinder valve		2 08 56 23					2 10 56 23		
	7.	4	In-/outlet sealing	2 08 70 03		2 10 70 08	2 10 70 10	2 10 70 03				
	17.	1	Exhaust muffler	Actual (coarse thread) ^{B)} 1 08 499 35 or 1 08 499 86 ^{C)}								
			Old (fine thread)	1 08 99 35 or 1 08 99 86 ^{C)}								
	28.	2	Plug upper sealing	2 08 78 03		2 10 78 08	2 10 78 10	2 10 78 03				
	29.	2	Plug lower sealing	2 08 478 03		2 10 478 08	2 10 478 10	2 10 478 03				
	SET 2 (wet and dry side)	13.	1	Air valve, thread mount	1 08 020 31 or 1 08 020 32							
				Air valve, circlip mount ^{D)}	1 08 20 31 or 1 08 20 32							
		22.	4	Valve seat, old type	2 08 54 20 (2 08 54 23)		2 10 54 20 (2 10 54 23)					
		22a.	4	Valve seat, new type ^{E)}			2 10 654 20 (2 10 654 23)					
		25.	2	Plug upper	2 08 055 20 (2 08 055 23)		2 10 055 20 (2 10 055 23)					
		26.	2	Valve stopper	2 08 39 20 (2 08 39 23)		2 10 39 20 (2 10 39 23)					
27.		2	Valve stopper bolt	2 08 38 20 (2 08 38 23)		2 10 38 20 (2 10 38 23)						

^{A)} - typical pump material executions (other material executions may require different spare parts);

^{B)} - actual exhaust muffler with coarse thread (implemented gradually from 2018), part number 1 08 499 35 (PE porous) or 1 08 499 86 (sintered bronze);

^{C)} - exhaust muffler from sintered bronze is available only on customer's request (standard execution is PE porous muffler);

^{D)} - circlip mounted air valve available for the pumps manufactured before August 2007 (pump's serial number verification required);

^{E)} - new type of valve seat (implemented gradually from January 2023 – new type of assembling/disassembling key [Item 97a] may be required).

5.2. DM 08/10 R.. DM 08/10 Z., DM 10/25 R., DM 10/25 Z.. (ATEX) – exploded view

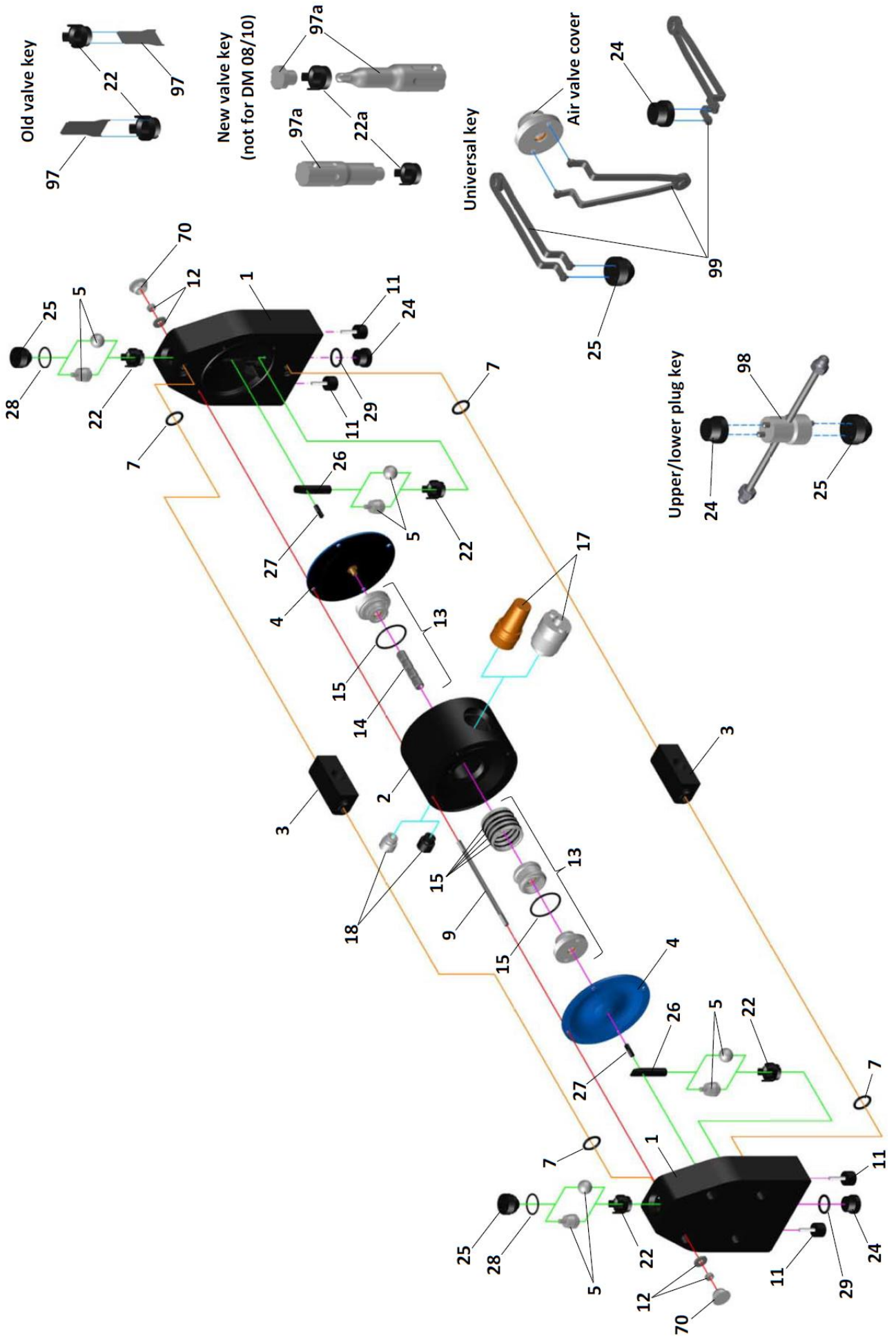

Spare parts list for DM 08/10 R., Z.. and DM 10/25 R., Z.. Plastic Series Pumps (with ATEX)

				Pump size and material execution (R-PE c., Z-PTFE c.)			
Item	Part name	Quantity	Material	DM 08/10 R..	DM 08/10 Z..	DM 10/25 R..	DM 10/25 Z..
1.	Pump housing	2	PE conductive	2 08 01 21		2 10 01 21	
			PTFE conductive		2 08 01 24		2 10 01 24
2.**	Central housing	1	PE conductive	1 08 10 21		1 10 10 21	
3.	Suction/discharge port	2	PE conductive	2 08 30 21		2 10 30 21	
			PTFE conductive		2 08 30 24		2 10 30 24
4.	Diaphragm	2	EPDM			1 10 50 08	
			NBR			1 10 50 10	
			TFM(PTFE)	1 08 50 05		1 10 50 05	
			TFM(PTFE)-PFA	1 08 50 00		1 10 50 00	
5.	Cylinder valves	4	PTFE	2 08 56 23		2 10 56 23	
	Ball valves	4	AISI 316	1 08 60 52		1 10 60 52	
			EPDM			1 10 60 08	
			NBR			1 10 60 10	
			PTFE	1 08 60 23		1 10 60 23	
			Ceramic			1 10 60 90	
7.*	In-/outlet sealing set	4	EPDM			2 10 70 08	
			FEP/Silicone core	2 08 70 03		2 10 70 03	
			FEP/FKM core	2 08 70 04		2 10 70 04	
			FKM			2 10 70 09	
			NBR			2 10 70 10	
9.	Housing bolt	4	AISI 304	2 08 042 50		2 10 042 50	
11.	Shock absorber	4	NR/Si37	1 08 69 06		1 10 69 06	
12.	Nut with washer set	8	AISI 304	2 08 045 50		2 10 045 50	
13.**	Air valve, complete (thread mount)	1	PET-NBR		1 08 020 31		
			PET-FKM		1 08 020 32		
14. ¹⁾	Air valve-diaphragm shaft	1	AISI 304	1 08 24 50			
15. ¹⁾	Air valve O-ring, external	6	NBR	1 08 080 10			
			FKM	1 08 080 09			
17.**	Exhaust muffler, old version	1	PE porous	1 08 99 35			
			Bronze (sintered)	1 08 99 86			
	Exhaust muffler, actual version	1	PE porous	1 08 499 35			
			Bronze (sintered)	1 08 499 86 ⁽²⁾			
18.**	Air adapter	1	PP	1 08 46 28			
			PE conductive	1 08 46 21 ⁽²⁾			
22.	Valve seat, old type (flat assembling key)	4	PE conductive	2 08 54 21		2 10 54 21	
			PTFE conductive		2 08 54 24		2 10 54 24
22a.	Valve seat, new type (new assembling key)	4	PE conductive			2 10 654 21	
			PTFE conductive				2 10 654 24
24.	Plug lower	2	PE conductive	2 08 59 21		2 10 59 21	
			PTFE conductive		2 08 59 24		2 10 59 24
25.	Plug upper	2	PE conductive	2 08 055 21		2 10 055 21	
			PTFE conductive		2 08 055 24		2 10 055 24
26.	Valve stopper	2	PE conductive	2 08 39 21		2 10 39 21	
			PTFE conductive		2 08 39 24		2 10 39 24
27.	Bolt	2	PE conductive	2 08 38 21		2 10 38 21	
			PTFE conductive		2 08 38 24		2 10 38 24
28.***	Plug upper sealing	2	EPDM			2 10 78 08	
			FEP/Silicone core	2 08 78 03		2 10 78 03	
			FEP/FKM core	2 08 78 04		2 10 78 04	
			FKM			2 10 78 09	
			NBR			2 10 78 10	
29.***	Plug lower sealing	2	EPDM			2 10 478 08	
			FEP/Silicone core	2 08 478 03		2 10 478 03	
			FEP/FKM core	2 08 478 04		2 10 478 04	
			FKM			2 10 478 09	
			NBR			2 10 478 10	
35.	Central housing complete	1	Diverse	1 08 11 21		1 10 11 21	
70.	Pump housing plug set	1	PE	2 08 058 20		2 10 058 20	
97.****	Valve seat key, flat (for 22.)	1	Structural steel	2 08 254 47		2 10 254 47	
97a.****	Valve seat key cpl (for 22a.)	1	Diverse			2 10 254C 00	
98.****	Upper/lower plug key	1	Diverse	1 08 158 00		1 10 158 00	
99.****	Universal key	1	Structural steel			1 10 58 00	

* - in-/outlet standard sealing O-rings material: EPDM for EPDM diaphragms, NBR for NBR diaphragms, FEP/Silicone (FEP encapsulated Silicone core) for TFM(PTFE) and TFM(PTFE)-PFA diaphragms;

** - parts included in Item 35 „Central housing complete“;

*** - plug upper standard sealing O-rings material: EPDM for EPDM diaphragms, NBR for NBR diaphragms, FEP/Silicone (FEP encapsulated Silicone core) for TFM(PTFE) and TFM(PTFE)-PFA diaphragms;

**** - available on request (not delivered with the pump nor with spare part kit sets) ;

¹⁾ - included in Item 13 „Air valve, complete“, but also can be ordered separately;

²⁾ - obligatory for “ATEX 0” (for detailed information, please refer to **Chapter 16.20**, page 82), but also can be ordered separately.

List of parts for spare part kits SET 1 and SET 2 in Plastic Series Pumps DM 08/10, DM 10/25 R.. (Z..) with ATEX

Spare part kit set type	Item	Quantity	Part description	Pump size							
				08/10				10/25			
				Material execution ^{A)}							
				RTT (ZTT)	RTF (ZTF)	RTS (ZTS)	REE (ZEE)	RNN (ZNN)	RTT (ZTT)	RTF (ZTF)	RTS (ZTS)
				Part number							
SET 1 (wet side)	4.	2	Diaphragm	1 08 50 05			1 10 50 08	1 10 50 10	1 10 50 05		
	5.	4	Valve ball	1 08 60 23		1 08 60 52	1 10 60 08	1 10 60 10	1 10 60 23		1 10 60 52
			Cylinder valve		2 08 56 23					2 10 56 23	
	7.	4	In-/outlet sealing	2 08 70 03			2 10 70 08	2 10 70 10	2 10 70 03		
	17.	1	Exhaust muffler	Actual (coarse thread) ^{B)}	1 08 499 35 or 1 08 499 86 ^{C)}						
				Old (fine thread)	1 08 99 35 or 1 08 99 86 ^{C)}						
	28.	2	Plug upper sealing	2 08 78 03			2 10 78 08	2 10 78 10	2 10 78 03		
	29.	2	Plug lower sealing	2 08 478 03			2 10 478 08	2 10 478 10	2 10 478 03		
	SET 2 (wet and dry side)	13.	1	Air valve, thread mount	1 08 020 31 or 1 08 020 32						
				Air valve, circlip mount ^{D)}	1 08 20 31 or 1 08 20 32						
		22.	4	Valve seat, old type	2 08 54 21 (2 08 54 24)			2 10 54 21 (2 10 54 24)			
		22a.	4	Valve seat, new type ^{E)}				2 10 654 21 (2 10 654 24)			
		25.	2	Plug upper	2 08 055 21 (2 08 055 24)			2 10 055 21 (2 10 055 24)			
		26.	2	Valve stopper	2 08 39 21 (2 08 39 24)			2 10 39 21 (2 10 39 24)			
27.		2	Valve stopper bolt	2 08 38 21 (2 08 38 24)			2 10 38 21 (2 10 38 24)				

- A) - typical pump material executions (other material executions may require different spare parts);
- B) - actual exhaust muffler with coarse thread (implemented gradually from 2018), part number 1 08 499 35 (PE porous) or 1 08 499 86 (sintered bronze);
- C) - exhaust muffler from sintered bronze is available only for "ATEX 0" (standard "ATEX" execution is PE porous muffler), or on customer's request;
- D) - circlip mounted air valve available for the pumps manufactured before August 2007 (pump's serial number verification required);
- E) - new type of valve seat (implemented gradually from January 2023 – new type of assembling/disassembling key [Item 97a.] may be required).

5.3. DM 15/55 P., DM 15/55 T., DM 25/125 P., DM 25/125 T.. – exploded view

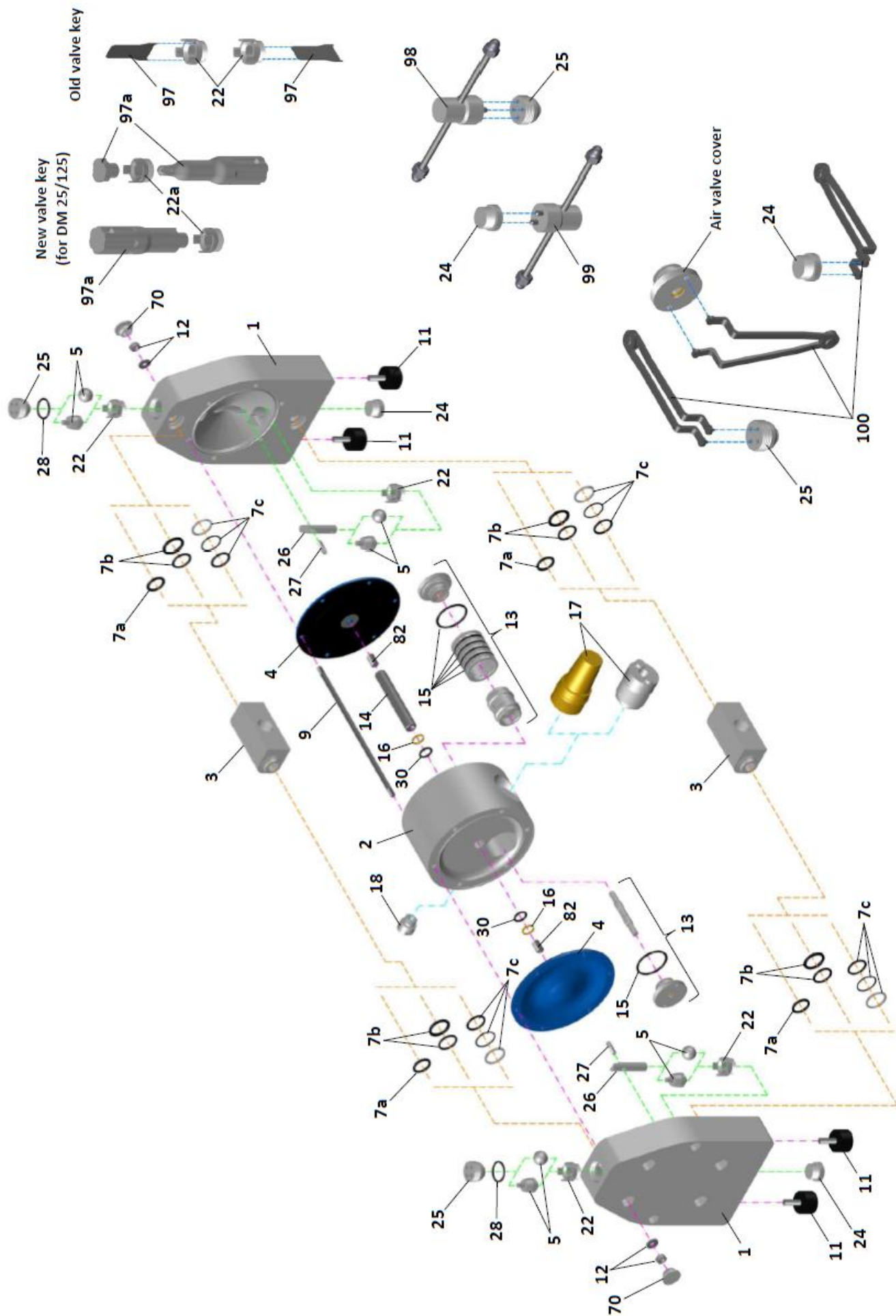

Spare parts list for DM 15/55 P., T.. and DM 25/125 P., T.. Plastic Series Pumps

				Pump size and material execution (P-PE, T-PTFE)					
Item	Part name	Quantity	Material	DM 15/55 P..	DM 15/55 T..	DM 25/125 P..	DM 25/125 T..		
1.	Pump housing	2	PE	2 15 01 20		2 25 01 20			
			PTFE		2 15 01 23		2 25 01 23		
2.**	Central housing	1	PE	1 15 10 20		1 25 10 20			
3.	Suction/discharge port	2	PE	2 15 30 20		2 25 30 20			
			PTFE		2 15 30 23		2 25 30 23		
4.	Diaphragm	2	EPDM	1 15 50 08		1 25 50 08			
			NBR	1 15 50 10		1 25 50 10			
			TFM(PTFE)	1 15 50 05		1 25 50 05			
			TFM(PTFE)-PFA	1 15 50 00		1 25 50 00			
5.	Cylinder valves	4	PTFE	2 15 56 23		2 25 56 23			
	Ball valves	4	AISI 316	1 15 60 52		1 25 60 52			
			EPDM	1 15 60 08		1 25 60 08			
			NBR	1 15 60 10		1 25 60 10			
			PTFE	1 15 60 23		1 25 60 23			
			FKM (FPM)	1 15 60 09		1 25 60 09			
			PU	1 15 60 07		1 25 60 07			
			Ceramic	1 15 60 90		1 25 60 90			
			7.*	a	In-/outlet sealing	4	EPDM	2 15 70 08	
FEP/FKM core	2 15 70 04								
FKM	2 15 70 09								
NBR	2 15 70 10								
b	In-/outlet sealing set	4		FEP/FKM core + FEP/FKM core			2 25 70 04		
				EPDM + EPDM			2 25 70 08		
				FKM + FKM			2 25 70 09		
c	In-/outlet sealing set	4		NBR + NBR			2 25 70 10		
				PTFE + FKM			2 25 73 14		
					PTFE + EPDM			2 25 73 15	
9.	Housing bolt	6		AISI 304	2 15 042 50		2 25 042 50		
11.	Shock absorber	4		NR/St37	1 15 69 06		1 25 69 06		
12.	Nut with washer set	12		AISI 304	2 15 045 50		2 25 045 50		
13.**	Air valve, complete (thread mount)	1	PET-NBR			1 15 020 31			
			PET-FKM			1 15 020 32			
14.**	Diaphragm shaft	1	AISI 304	1 15 440 50		1 25 440 50			
15. ¹⁾	Air valve O-ring, external	6	NBR			1 15 080 10			
			FKM			1 15 080 09			
16.**	Central housing seal	2	PE	1 15 85 22		1 25 85 22			
17.**	Exhaust muffler, old version	1	PE porous			1 15 99 35			
			Bronze (sintered)			1 15 99 86			
	Exhaust muffler, actual version	1	PE porous			1 15 499 35			
			Bronze (sintered)			1 15 499 86			
18.**	Air adapter	1	PP			1 15 46 28			
22.	Valve seat, old type	4	PE	2 15 54 20		2 25 54 20			
			PTFE		2 15 54 23		2 25 54 23		
22a.	Valve seat, new type	4	PE			2 25 654 20			
			PTFE			2 25 654 23			
24.	Plug lower	2	PE	2 15 59 20		2 25 59 20			
			PTFE		2 15 59 23		2 25 59 23		
25.	Plug upper	2	PE	2 15 055 20		2 25 055 20			
			PTFE		2 15 055 23		2 25 055 23		
26.	Valve stopper	2	PE	2 15 39 20		2 25 39 20			
			PTFE		2 15 39 23		2 25 39 23		
27.	Bolt	2	PE	2 15 38 20		2 25 38 20			
			PTFE		2 15 38 23		2 25 38 23		
28.***	Plug upper sealing	2	EPDM	2 15 78 08		2 25 78 08			
			FEP/Silicone core	2 15 78 03		2 25 78 03			
			FEP/FKM core	2 15 78 04		2 25 78 04			
			FKM	2 15 78 09		2 25 78 09			
			NBR	2 15 78 10		2 25 78 10			
30.**	Central housing O-ring	2/4 (a)	NBR	1 15 85 10		1 25 85 10 (a)			
35.	Central housing complete	1	Diverse	1 15 11 20		1 25 11 20			
70.	Pump housing plug set	1	PE	2 15 058 20		2 25 058 20			
82.	Shaft allen pin screw	2	AISI 304	1 15 540 50		1 25 540 50			
97.****	Valve seat key, old	1	Structural steel	2 15 254 47		2 25 254 47			
97a.****	Valve seat key cpl., new		Diverse	2 15 254C 00		2 25 254C 00			
98.****	Plug upper key	1	Diverse	2 15 758 00		2 25 758 00			
99.****	Plug lower key	1	Diverse	2 15 858 00		2 25 858 00			
100.****	Universal key	1	Structural steel			1 10 58 00			

* - in-/outlet standard sealing material for **DM 15/55**: EPDM O-ring for EPDM diaphragms, NBR O-ring for NBR diaphragms, FEP/FKM O-ring for TFM(PTFE) and TFM(PTFE)-PFA diaphragms; for **DM 25/125**: EPDM O-rings for EPDM diaphragms, NBR O-rings for NBR diaphragms, PTFE gasket + EPDM O-rings for TFM(PTFE) and TFM(PTFE)-PFA diaphragms;

** - parts included in Item 35 „Central housing complete“;

*** - plug upper standard sealing O-rings material: EPDM for EPDM diaphragms, NBR for NBR diaphragms, FEP/Silicone (FEP encapsulated Silicone core) for TFM(PTFE) and TFM(PTFE)-PFA diaphragms;

**** - available on request (not delivered with the pump nor with spare part kit sets);

¹⁾ - included in Item 13 „Air valve, complete“, but also can be ordered separately.

List of parts for spare part kits SET 1 and SET 2 in Plastic Series Pumps DM 15/55 P.. (T..)

Spare part kit set type	Item	Quantity	Part description	Pump size DM 15/55								
				Material execution ^{A)}								
				PEE (TEE)	PNN (TNN)	PTT (TTT)	PTF (TTF)	PTS (TTS)	PFT (TFT)	PTC (TTC)	PTU (TTU)	
				Part number								
SET 2 (wet and dry side)	SET 1 (wet side)	4.	2	Diaphragm	1 15 50 08	1 15 50 10	1 15 50 05		1 15 50 00	1 15 50 05		
		5.	4	Valve ball	1 15 60 08	1 15 60 10	1 15 60 23		1 15 60 52	1 15 60 23	1 15 60 90	1 15 60 07
				Cylinder valve				2 15 56 23				
		7.	4	In-/outlet sealing	2 15 70 08	2 15 70 10	2 15 70 04					
		17.	1	Exhaust muffler	Actual (coarse thread) ^{B)}	1 15 499 35 or 1 15 499 86 ^{C)}						
	Old (fine thread)				1 15 99 35 or 1 15 99 86 ^{C)}							
	28.	2	Plug upper sealing	2 15 78 08	2 15 78 10	2 15 78 03						
	13.	1	Air valve, thread mount	1 15 020 31 or 1 15 020 32								
			Air valve, circlip mount ^{D)}	1 15 20 31 or 1 15 20 32								
	14.	1	Diaphragm shaft	1 15 440 50								
	16.	2	Central housing seal	1 15 85 22								
	22.	4	Valve seat, old type	2 15 54 20 (2 15 54 23)								
	22a.	4	Valve seat, new type ^{E)}	2 15 654 20 (2 15 654 23)								
	25.	2	Plug upper	2 15 055 20 (2 15 055 23)								
	26.	2	Valve stopper	2 15 39 20 (2 15 39 23)								
	27.	2	Valve stopper bolt	2 15 38 20 (2 15 38 23)								
	30.	2	Central housing O-ring	1 15 85 10								
	82.	2	Shaft allen pin screw	1 15 540 50								

- A) - typical pump material executions (other material executions may require different spare parts);
 B) - actual exhaust muffler with coarse thread (implemented gradually from 2018), part number 1 15 499 35 (PE porous) or 1 15 499 86 (sintered bronze);
 C) - exhaust muffler from sintered bronze is available only on customer's request (standard execution is PE porous muffler);
 D) - circlip mounted air valve available for the pumps manufactured before August 2007 (pump's serial number verification required);
 E) - new type of valve seat (implemented gradually from January 2023 – new type of assembling/disassembling key [Item 97a] may be required).

List of parts for spare part kits SET 1 and SET 2 in Plastic Series Pumps DM 25/125 P.. (T..)

Spare part kit set type	Item	Quantity	Part description	Pump size DM 25/125								
				Material execution ^{A)}								
				PEE (TEE)	PNN (TNN)	PTT (TTT)	PTF (TTF)	PTS (TTS)	PFT (TFT)	PTC (TTC)	PTU (TTU)	
				Part number								
SET 2 (wet and dry side)	SET 1 (wet side)	4.	2	Diaphragm	1 25 50 08	1 25 50 10	1 25 50 05		1 25 50 00	1 25 50 05		
		5.	4	Valve ball	1 25 60 08	1 25 60 10	1 25 60 23		1 25 60 52	1 25 60 23	1 25 60 90	1 25 60 07
				Cylinder valve				2 25 56 23				
		7.	4	In-/outlet sealing	2 25 70 08	2 25 70 10	2 25 73 15					
		17.	1	Exhaust muffler	Actual (coarse thread) ^{B)}	1 15 499 35 or 1 15 499 86 ^{C)}						
	Old (fine thread)				1 15 99 35 or 1 15 99 86 ^{C)}							
	28.	2	Plug upper sealing	2 25 78 08	2 25 78 10	2 25 78 03						
	13.	1	Air valve, thread mount	1 15 020 31 or 1 15 020 32								
			Air valve, circlip mount ^{D)}	1 15 20 31 or 1 15 20 32								
	14.	1	Diaphragm shaft	1 25 440 50								
	16.	2	Central housing seal	1 25 85 22								
	22.	4	Valve seat, old type	2 25 54 20 (2 25 54 23)								
	22a.	4	Valve seat, new type ^{E)}	2 25 654 20 (2 25 654 23)								
	25.	2	Plug upper	2 25 055 20 (2 25 055 23)								
	26.	2	Valve stopper	2 25 39 20 (2 25 39 23)								
	27.	2	Valve stopper bolt	2 25 38 20 (2 25 38 23)								
	30.	4	Central housing O-ring	1 25 85 10								
	82.	2	Shaft allen pin screw	1 25 540 50								

- A) - typical pump material executions (other material executions may require different spare parts);
 B) - actual exhaust muffler with coarse thread (implemented gradually from 2018), part number 1 15 499 35 (PE porous) or 1 15 499 86 (sintered bronze);
 C) - exhaust muffler from sintered bronze is available only on customer's request (standard execution is PE porous muffler);
 D) - circlip mounted air valve available for the pumps manufactured before August 2007 (pump's serial number verification required);
 E) - new type of valve seat (without notches) implemented gradually from October 2022 (pump part's visual verification required).

5.4. DM 15/55 R., DM 15/55 Z., DM 25/125 R., DM 25/125 Z.. (ATEX) – exploded view

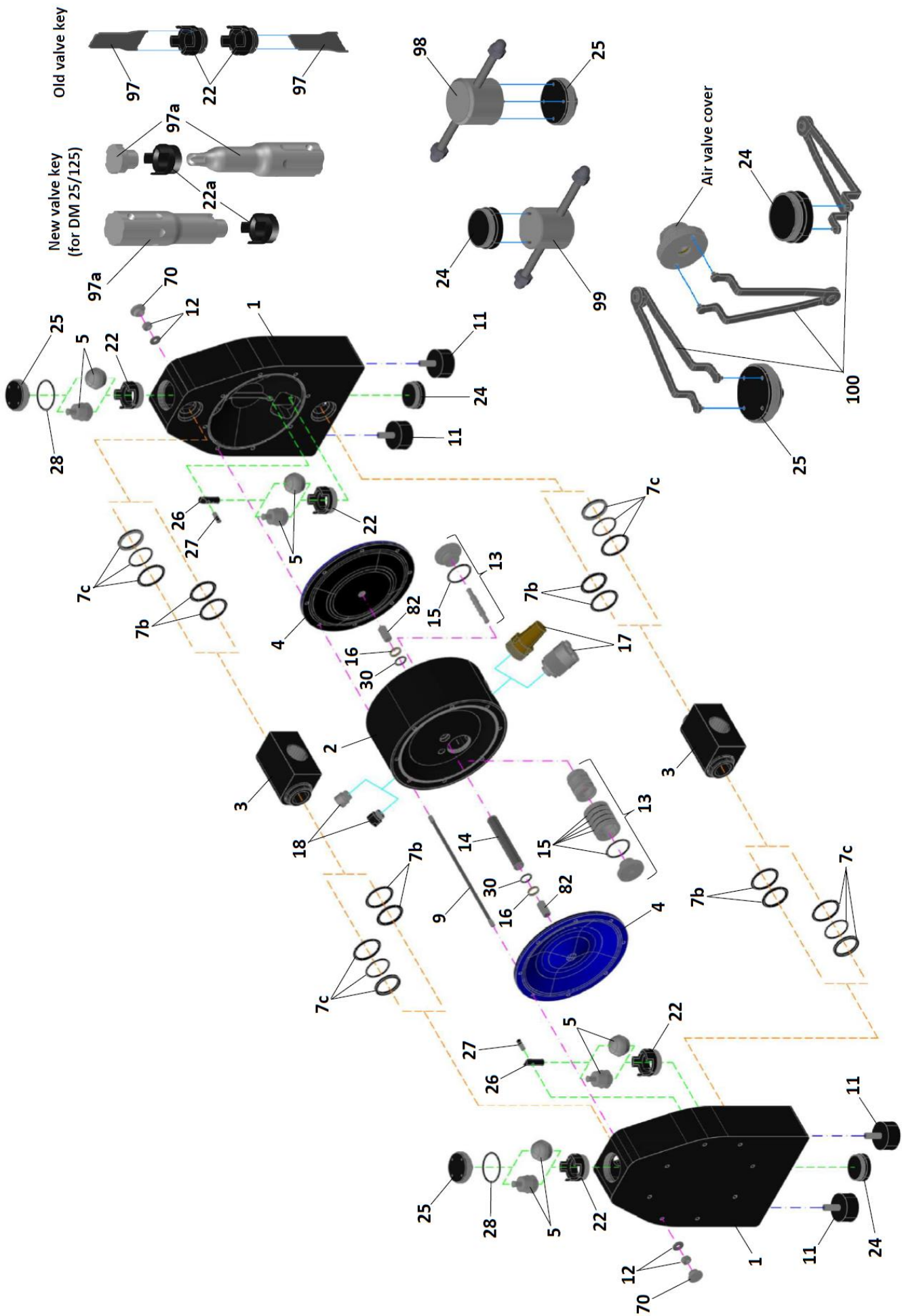

Spare parts list for DM 15/55 R., Z.. and DM 25/125 R., Z.. Plastic Series Pumps (with ATEX)

				Pump size and material execution (R-PE c., Z-PTFE c.)			
Item	Part name	Quantity	Material	DM 15/55 R..	DM 15/55 Z..	DM 25/125 R..	DM 25/125 Z..
1.	Pump housing	2	PE conductive	2 15 01 21		2 25 01 21	
			PTFE conductive		2 15 01 24		2 25 01 24
2.**	Central housing	1	PE conductive	1 15 10 21		1 25 10 21	
3.	Suction/discharge port	2	PE conductive	2 15 30 21		2 25 30 21	
			PTFE conductive		2 15 30 24		2 25 30 24
4.	Diaphragm	2	EPDM	1 15 50 08		1 25 50 08	
			NBR	1 15 50 10		1 25 50 10	
			TFM(PTFE)	1 15 50 05		1 25 50 05	
			TFM(PTFE)-PFA	1 15 50 00		1 25 50 00	
5.	Cylinder valves	4	PTFE	2 15 56 23		2 25 56 23	
			AISI 316	1 15 60 52		1 25 60 52	
	Ball valves	4	EPDM	1 15 60 08		1 25 60 08	
			NBR	1 15 60 10		1 25 60 10	
			PTFE	1 15 60 23		1 25 60 23	
			FKM (FPM)	1 15 60 09		1 25 60 09	
			PU	1 15 60 07		1 25 60 07	
			Ceramic	1 15 60 90		1 25 60 90	
7.*	a	In-/outlet sealing	4	EPDM	2 15 70 08		
				FEP/FKM core	2 15 70 04		
				FKM	2 15 70 09		
				NBR	2 15 70 10		
	b	In-/outlet sealing set	4	FEP/FKM core + FEP/FKM core			2 25 70 04
				EPDM + EPDM			2 25 70 08
				FKM + FKM			2 25 70 09
	c	In-/outlet sealing set	4	PTFE conductive + FKM			2 25 73 16
				PTFE conductive + EPDM			2 25 73 17
9.	Housing bolt	6	AISI 304	2 15 042 50		2 25 042 50	
11.	Shock absorber	4	NR/St37	1 15 69 06		1 25 69 06	
12.	Nut with washer set	12	AISI 304	2 15 045 50		2 25 045 50	
13.**	Air valve, complete (thread mount)	1	PET-NBR	1 15 020 31			
			PET-FKM	1 15 020 32			
14.**	Diaphragm shaft	1	AISI 304	1 15 440 50		1 25 440 50	
15. ¹⁾	Air valve O-ring, external	6	NBR	1 15 080 10			
			FKM	1 15 080 09			
16.**	Central housing seal	2	PE	1 15 85 22		1 25 85 22	
17.**	Exhaust muffler, old version	1	PE porous	1 15 99 35			
			Bronze (sintered)	1 15 99 86			
	Exhaust muffler, new version	1	PE porous	1 15 499 35			
			Bronze (sintered)	1 15 499 86 ⁽²⁾			
18.**	Air adapter	1	PP	1 15 46 28			
			PE conductive	1 15 46 21 ⁽²⁾			
22.	Valve seat, old type	4	PE conductive	2 15 54 21		2 25 54 21	
			PTFE conductive		2 15 54 24		2 25 54 24
22a.	Valve seat, new type	4	PE conductive			2 25 654 21	
			PTFE conductive				2 25 654 24
24.	Plug lower	2	PE conductive	2 15 59 21		2 25 59 21	
			PTFE conductive		2 15 59 24		2 25 59 24
25.	Plug upper	2	PE conductive	2 15 055 21		2 25 055 21	
			PTFE conductive		2 15 055 24		2 25 055 24
26.	Valve stopper	2	PE conductive	2 15 39 21		2 25 39 21	
			PTFE conductive		2 15 39 24		2 25 39 24
27.	Bolt	2	PE conductive	2 15 38 21		2 25 38 21	
			PTFE conductive		2 15 38 24		2 25 38 24
28.***	Plug upper sealing	2	EPDM	2 15 78 08		2 25 78 08	
			FEP/Silicone core	2 15 78 03		2 25 78 03	
			FEP/FKM core	2 15 78 04		2 25 78 04	
			FKM	2 15 78 09		2 25 78 09	
			NBR	2 15 78 10		2 25 78 10	
30.**	Central housing O-ring	2/4 ^(a)	NBR	1 15 85 10		1 25 85 10 ^(a)	
35.	Central housing, complete	1	Diverse	1 15 11 21		1 25 11 21	
70.	Pump housing plug set	1	PE	2 15 058 20		2 25 058 20	
82.	Shaft allen pin screw	2	AISI 304	1 15 540 50		1 25 540 50	
97.****	Valve seat key, old	1	Structural steel	2 15 254 47		2 25 254 47	
97a.****	Valve seat key cpl., new	1	Diverse	2 15 254C 00		2 25 254C 00	
98.****	Plug upper key	1	Diverse	2 15 758 00		2 25 758 00	
99.****	Plug lower key	1	Diverse	2 15 858 00		2 25 858 00	
100.****	Universal key	1	Structural steel	1 10 58 00			

* - in-/outlet standard sealing material for **DM 15/55**: EPDM O-ring for EPDM diaphragms, NBR O-ring for NBR diaphragms, FEP/FKM O-ring for TFM(PTFE) and TFM(PTFE)-PFA diaphragms; for **DM 25/125**: EPDM O-rings for EPDM diaphragms, NBR O-rings for NBR diaphragms, PTFE gasket + EPDM O-rings for TFM(PTFE) and TFM(PTFE)-PFA diaphragms;

** - parts included in Item 35 „Central housing complete“;

*** - plug upper standard sealing O-rings material: EPDM for EPDM diaphragms, NBR for NBR diaphragms, FEP/Silicone (FEP encapsulated Silicone core) for TFM(PTFE) and TFM(PTFE)-PFA diaphragms;

**** - available on request (not delivered with the pump nor with spare part kit sets);

¹⁾ - included in Item 13 „Air valve, complete“, but also can be ordered separately;

²⁾ - obligatory for “ATEX 0” (for detailed information, please refer to **Chapter 16.20**, page **82**), but also can be ordered separately.

List of parts for spare part kits SET 1 and SET 2 in Plastic Series Pumps DM 15/55 R.. (Z..) with ATEX

Spare part kit set type	Item	Quantity	Part description	Pump size DM 15/55									
				Material execution ^{A)}									
				REE (ZEE)	RNN (ZNN)	RTT (ZTT)	RTF (ZTF)	RTS (ZTS)	RFT (ZFT)	RTC (ZTC)	RTU (ZTU)		
				Part number									
SET 2 (wet and dry side)	SET 1 (wet side)	4.	2	Diaphragm	1 15 50 08	1 15 50 10	1 15 50 05		1 15 50 00	1 15 50 05			
		5.	4	Valve ball	1 15 60 08	1 15 60 10	1 15 60 23		1 15 60 52	1 15 60 23	1 15 60 90	1 15 60 07	
				Cylinder valve				2 15 56 23					
		7.	4	In-/outlet sealing	2 15 70 08	2 15 70 10	2 15 70 04						
		17.	1	Exhaust muffler	Actual (coarse thread) ^{B)}	1 15 499 35 or 1 15 499 86 ^{C)}							
					Old (fine thread)	1 15 99 35 or 1 15 99 86 ^{C)}							
	28.	2	Plug upper sealing	2 15 78 08	2 15 78 10	2 15 78 03							
	13.	1	Air valve, thread mount	1 15 020 31 or 1 15 020 32									
			Air valve, circlip mount ^{D)}	1 15 20 31 or 1 15 20 32									
	14.	1	Diaphragm shaft	1 15 440 50									
	16.	2	Central housing seal	1 15 85 22									
	22.	4	Valve seat, old type	2 15 54 21 (2 15 54 24)									
	22a.	4	Valve seat, new type ^{E)}	2 15 654 21 (2 15 654 24)									
	25.	2	Plug upper	2 15 055 21 (2 15 055 24)									
	26.	2	Valve stopper	2 15 39 21 (2 15 39 24)									
	27.	2	Valve stopper bolt	2 15 38 21 (2 15 38 24)									
	30.	2	Central housing O-ring	1 15 85 10									
	82.	2	Shaft allen pin screw	1 15 540 50									

- A) - typical pump material executions (other material executions may require different spare parts);
 B) - actual exhaust muffler with coarse thread (implemented gradually from 2018), part number 1 15 499 35 (PE porous) or 1 15 499 86 (sintered bronze);
 C) - exhaust muffler from sintered bronze is available only for "ATEX 0" (standard "ATEX" execution is PE porous muffler), or on customer's request;
 D) - circlip mounted air valve available for the pumps manufactured before August 2007 (pump's serial number verification required);
 E) - new type of valve seat (without notches) implemented gradually from January 2023 (pump part's visual verification required).

List of parts for spare part kits SET 1 and SET 2 in Plastic Series Pumps DM 25/125 R.. (Z..) with ATEX

Spare part kit set type	Item	Quantity	Part description	Pump size DM 25/125									
				Material execution ^{A)}									
				REE (ZEE)	RNN (ZNN)	RTT (ZTT)	RTF (ZTF)	RTS (ZTS)	RFT (ZFT)	RTC (ZTC)	RTU (ZTU)		
				Part number									
SET 2 (wet and dry side)	SET 1 (wet side)	4.	2	Diaphragm	1 25 50 08	1 25 50 10	1 25 50 05		1 25 50 00	1 25 50 05			
		5.	4	Valve ball	1 25 60 08	1 25 60 10	1 25 60 23		1 25 60 52	1 25 60 23	1 25 60 90	1 25 60 07	
				Cylinder valve				2 25 56 23					
		7.	4	In-/outlet sealing	2 25 70 08	2 25 70 10	2 25 73 17						
		17.	1	Exhaust muffler	Actual (coarse thread) ^{B)}	1 15 499 35 or 1 15 499 86 ^{C)}							
					Old (fine thread)	1 15 99 35 or 1 15 99 86 ^{C)}							
	28.	2	Plug upper sealing	2 25 78 08	2 25 78 10	2 25 78 03							
	13.	1	Air valve, thread mount	1 15 020 31 or 1 15 020 32									
			Air valve, circlip mount ^{D)}	1 15 20 31 or 1 15 20 32									
	14.	1	Diaphragm shaft	1 25 440 50									
	16.	2	Central housing seal	1 25 85 22									
	22.	4	Valve seat, old type	2 25 54 21 (2 25 54 24)									
	22a.	4	Valve seat, new type ^{E)}	2 25 654 21 (2 25 654 24)									
	25.	2	Plug upper	2 25 055 23 (2 25 055 24)									
	26.	2	Valve stopper	2 25 39 23 (2 25 39 24)									
	27.	2	Valve stopper bolt	2 25 38 23 (2 25 38 24)									
	30.	4	Central housing O-ring	1 25 85 10									
	82.	2	Shaft allen pin screw	1 25 540 50									

- A) - typical pump material executions (other material executions may require different spare parts);
 B) - actual exhaust muffler with coarse thread (implemented gradually from 2018), part number 1 15 499 35 (PE porous) or 1 15 499 86 (sintered bronze);
 C) - exhaust muffler from sintered bronze is available only for "ATEX 0" (standard "ATEX" execution is PE porous muffler), or on customer's request;
 D) - circlip mounted air valve available for the pumps manufactured before August 2007 (pump's serial number verification required);
 E) - new type of valve seat (without notches) implemented gradually from October 2022 (pump part's visual verification required).

5.5. DM 40/315 P., DM 40/315 T., DM 50/565 P., DM 50/565 T.. – exploded view

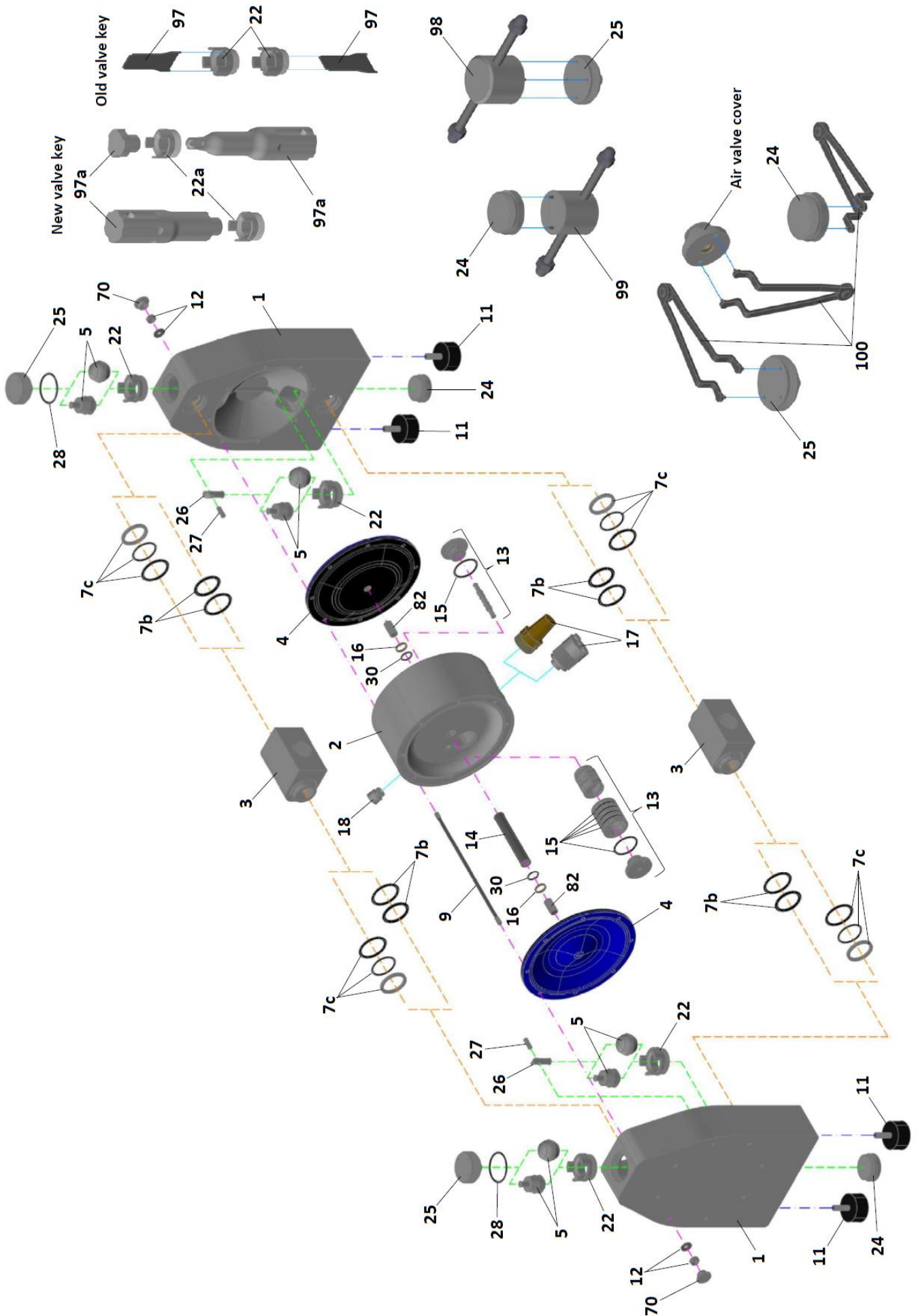

Spare parts list for DM 40/315 P., T.. and DM 50/565 P., T.. Plastic Series Pumps

				Pump size and material execution (P-PE, T-PTFE)			
Item	Part name	Quantity	Material	DM 40/315 P..	DM 40/315 T..	DM 50/565 P..	DM 50/565 T..
1.	Pump housing	2	PE	2 40 01 20		2 50 01 20	
			PTFE		2 40 01 23		2 50 01 23
2.**	Central housing	1	PE	1 40 10 20		1 50 10 20	
3.	Suction/discharge port	2	PE	2 40 30 20		2 50 30 20	
			PTFE		2 40 30 23		2 50 30 23
4.	Diaphragm	2	EPDM	1 40 50 08		1 50 50 08	
			NBR	1 40 50 10		1 50 50 10	
			TFM(PTFE)	1 40 50 05		1 50 50 05	
			TFM(PTFE)-PFA	1 40 50 00			
5.	Cylinder valves	4	PTFE	2 40 56 23		2 50 56 23	
	Ball valves	4	AISI 316	1 40 60 52		1 50 60 52	
			EPDM	1 40 60 08		1 50 60 08	
			NBR	1 40 60 10		1 50 60 10	
			PTFE	1 40 60 23		1 50 60 23	
			FPM (FKM)	1 40 60 09			
			PU	1 40 60 07		1 50 60 07	
7.*	b	In-/outlet sealing set	4	FEP/FKM core + FEP/FKM core	2 40 70 04		2 50 70 04
				EPDM + EPDM	2 40 70 08		2 50 70 08
				FKM + FKM	2 40 70 09		2 50 70 09
				NBR + NBR	2 40 70 10		2 50 70 10
	c	In-/outlet sealing set	4	PTFE + FKM	2 40 73 14		2 50 73 14
				PTFE + EPDM	2 40 73 15		2 50 73 15
9.	Housing bolt	8	AISI 304	2 40 042 50		2 50 042 50	
11.	Shock absorber	4	NR/St37	1 40 69 06		1 40 69 06	
12.	Nut with washer set	16	AISI 304	2 40 045 50		2 50 045 50	
13.**	Air valve, complete (thread mount)	1	PET-NBR	1 40 020 31			
			PET-FKM	1 40 020 32			
14.**	Diaphragm shaft	1	AISI 304	1 40 440 50		1 50 440 50	
15. ¹⁾	Air valve O-ring, external	6	NBR	1 40 080 10			
			FKM	1 40 080 09			
16.**	Central housing seal	2	PE	1 40 85 22		1 50 85 22	
17.**	Exhaust muffler, old version	1	PE porous	1 40 99 35		1 50 99 35	
			Bronze (sintered)	1 40 99 86		1 50 99 86	
	Exhaust muffler, actual version	1	PE porous	1 40 499 35		1 50 499 35	
			Bronze (sintered)	1 40 499 86		1 50 499 86	
18.**	Air adapter	1	PP	1 40 46 28			
22.	Valve seat, old type	4	PE	2 40 54 20		2 50 54 20	
			PTFE		2 40 54 23		2 50 54 23
22a.	Valve seat, new type	4	PE	2 40 654 20		2 50 654 20	
			PTFE		2 40 654 23		2 50 654 23
24.	Plug lower	2	PE	2 40 59 20		2 50 59 20	
			PTFE		2 40 59 23		2 50 59 23
25.	Plug upper	2	PE	2 40 055 20		2 50 055 20	
			PTFE		2 40 055 23		2 50 055 23
26.	Valve stopper	2	PE	2 40 39 20		2 50 39 20	
			PTFE		2 40 39 23		2 50 39 23
27.	Bolt	2	PE	2 40 38 20		2 50 38 20	
			PTFE		2 40 38 23		2 50 38 23
28.***	Plug upper sealing	2	EPDM	2 40 78 08		2 50 78 08	
			FEP/Silicone core	2 40 78 03			
			FEP/FKM core	2 40 78 04		2 50 78 04	
			FKM	2 40 78 09		2 50 78 09	
			NBR	2 40 78 10		2 50 78 10	
30.**	Central housing O-ring	2	NBR	1 40 85 10		1 50 85 10	
35.	Central housing complete	1	Diverse	1 40 11 20		1 50 11 20	
70.	Pump housing plug set	1	PE	2 40 058 20		2 50 058 20	
82.	Shaft allen pin screw	2	AISI 304	1 40 540 50		1 50 540 50	
97.****	Valve seat key, old	1	Structural steel	2 40 254 47		2 50 254 47	
97a.****	Valve seat key cpl., new	1	Diverse	2 40 254C 00		2 50 254C 00	
98.****	Plug upper key	1	Diverse	2 40 758 00		2 50 758 00	
99.****	Plug lower key	1	Diverse	2 40 858 00		2 50 858 00	
100.****	Universal key	1	Structural steel	1 10 58 00			

* - in-/outlet standard sealing material: EPDM O-rings for EPDM diaphragms, NBR O-rings for NBR diaphragms, PTFE gaskets + EPDM O-rings for TFM(PTFE) and TFM(PTFE)-PFA diaphragms;

** - parts included in Item 35 „Central housing complete“;

*** - plug upper standard sealing O-rings material: EPDM for EPDM diaphragms, NBR for NBR diaphragms, FEP/Silicone (FEP encapsulated silicone core) for TFM(PTFE) and TFM(PTFE)-PFA diaphragms in DM 40/315 Pumps or FEP/FKM (FEP encapsulated FKM core) for TFM(PTFE) and TFM(PTFE)-PFA diaphragms in DM 50/565 Pumps;

**** - available on request (not delivered with the pump nor with spare part kit sets);

⁽¹⁾ - included in Item 13 „Air valve, complete“, but also can be ordered separately.

List of parts for spare part kits SET 1 and SET 2 in Plastic Series Pumps DM 40/315 P.. (T..)

Spare part kit set type	Item	Quantity	Part description	Pump size DM 40/315							
				Material execution ^{A)}							
				PEE (TEE)	PNN (TNN)	PTT (TTT)	PTF (TTF)	PTS (TTS)	PFT (TFT)	PTU (TTU)	
				Part number							
SET 2 (wet and dry side)	SET 1 (wet side)	4.	2	Diaphragm	1 40 50 08	1 40 50 10	1 40 50 05		1 40 50 00	1 40 50 05	
		5.	4	Valve ball	1 40 60 08	1 40 60 10	1 40 60 23		1 40 60 52	1 40 60 23	1 40 60 07
				Cylinder valve				2 40 56 23			
		7.	4	In-/outlet sealing	2 40 70 08	2 40 70 10	2 40 73 15				
		17.	1	Exhaust muffler	Actual (coarse thread) ^{B)}	1 40 499 35 or 1 40 499 86 ^{C)}					
	Old (fine thread)				1 40 99 35 or 1 40 99 86 ^{C)}						
	28.	2	Plug upper sealing	2 40 78 08	2 40 78 10	2 40 78 03					
	SET 2 (wet and dry side)	13.	1	Air valve, thread mount	1 40 020 31 or 1 40 020 32						
				Air valve, circlip mount ^{D)}	1 40 20 31 or 1 40 20 32						
		14.	1	Diaphragm shaft	1 40 440 50						
		16.	2	Central housing seal	1 40 85 22						
		22.	4	Valve seat, old type	2 40 54 20 (2 40 54 23)						
		22a.		Valve seat, new type	2 40 654 20 (2 40 654 23)						
		25.	2	Plug upper	2 40 055 20 (2 40 055 23)						
		26.	2	Valve stopper	2 40 39 20 (2 40 39 23)						
		27.	2	Valve stopper bolt	2 40 38 20 (2 40 38 23)						
		30.	2	Central housing O-ring	1 40 85 10						
	82.	2	Shaft allen pin screw	1 40 540 50							

- A) - typical pump material executions (other material executions may require different spare parts);
- B) - actual exhaust muffler with coarse thread (implemented gradually from 2018), part number 1 40 499 35 (PE porous) or 1 40 499 86 (sintered bronze);
- C) - exhaust muffler from sintered bronze is available only on customer's request (standard execution is PE porous muffler);
- D) - circlip mounted air valve available for the pumps manufactured before August 2007 (pump's serial number verification required);
- E) - new type of valve seat (without notches) implemented gradually from January 2023 (pump part's visual verification required).

List of parts for spare part kits SET 1 and SET 2 in Plastic Series Pumps DM 50/565 P.. (T..)

Spare part kit set type	Item	Quantity	Part description	Pump size DM 50/565							
				Material execution ^{A)}							
				PEE (TEE)	PNN (TNN)	PTT (TTT)	PTF (TTF)	PTS (TTS)	PTU (TTU)		
				Part number							
SET 2 (wet and dry side)	SET 1 (wet side)	4.	2	Diaphragm	1 50 50 08	1 50 50 10	1 50 50 05		1 50 50 05		
		5.	4	Valve ball	1 50 60 08	1 50 60 10	1 50 60 23		1 50 60 52	1 50 60 07	
				Cylinder valve				2 50 56 23			
		7.	4	In-/outlet sealing	2 50 70 08	2 50 70 10	2 50 73 15				
		17.	1	Exhaust muffler	Actual (coarse thread) ^{B)}	1 50 499 35 or 1 50 499 86 ^{C)}					
	Old (fine thread)				1 50 99 35 or 1 50 99 86 ^{C)}						
	28.	2	Plug upper sealing	2 50 78 08	2 50 78 10	2 50 78 04					
	SET 2 (wet and dry side)	13.	1	Air valve, thread mount	1 40 020 31 or 1 40 020 32						
				Air valve, circlip mount ^{D)}	1 40 20 31 or 1 40 20 32						
		14.	1	Diaphragm shaft	1 50 440 50						
		16.	2	Central housing seal	1 50 85 22						
		22.	4	Valve seat, old type	2 50 54 20 (2 50 54 23)						
		22a.		Valve seat, new type ^{E)}	2 50 654 20 (2 50 654 23)						
		25.	2	Plug upper	2 50 055 20 (2 50 055 23)						
		26.	2	Valve stopper	2 50 39 20 (2 50 39 23)						
		27.	2	Valve stopper bolt	2 50 38 20 (2 50 38 23)						
		30.	2	Central housing O-ring	1 50 85 10						
	82.	2	Shaft allen pin screw	1 50 540 50							

- A) - typical pump material executions (other material executions may require different spare parts);
- B) - actual exhaust muffler with coarse thread (implemented gradually from 2018), part number 1 50 499 35 (PE porous) or 1 50 499 86 (sintered bronze);
- C) - exhaust muffler from sintered bronze is available only on customer's request (standard execution is PE porous muffler);
- D) - circlip mounted air valve available for the pumps manufactured before August 2007 (pump's serial number verification required);
- E) - new type of valve seat (without notches) implemented gradually from January 2023 (pump part's visual verification required).

5.6. DM 40/315 R., DM 40/315 Z., DM 50/565 R., DM 50/565 Z. (ATEX) – exploded view

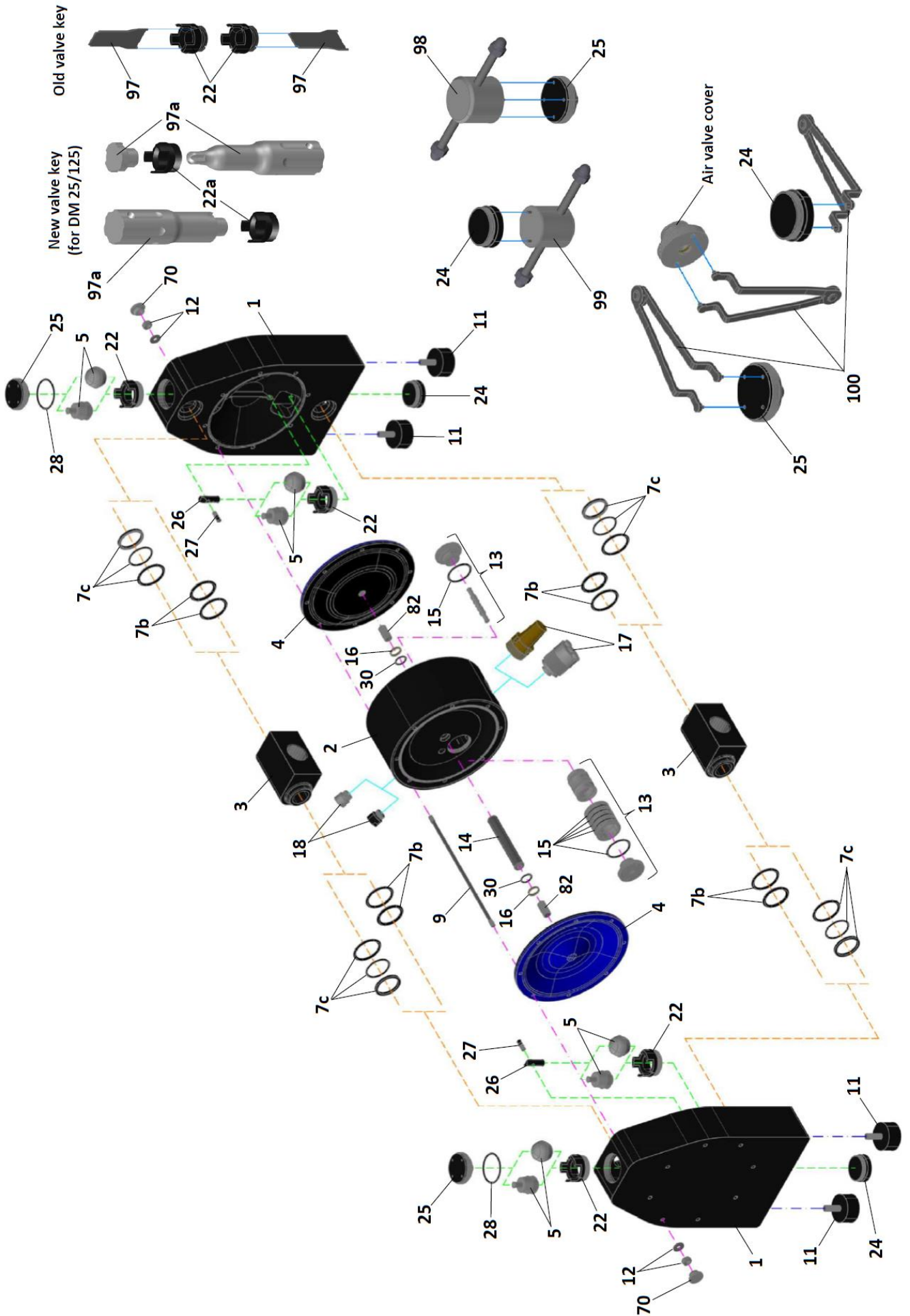

Spare parts list for DM 40/315 R., Z.. and DM 50/565 R., Z.. Plastic Series Pumps (with ATEX)

				Pump size and material execution (R-PE c., Z-PTFE c.)			
Item	Part name	Quantity	Material	DM 40/315 R..	DM 40/315 Z..	DM 50/565 R..	DM 50/565 Z..
1.	Pump housing	2	PE conductive	2 40 01 21		2 50 01 21	
			PTFE conductive		2 40 01 24		2 50 01 24
2.**	Central housing	1	PE conductive	1 40 10 21		1 50 10 21	
3.	Suction/discharge port	2	PE conductive	2 40 30 21		2 50 30 21	
			PTFE conductive		2 40 30 24		2 50 30 24
4.	Diaphragm	2	EPDM	1 40 50 08		1 50 50 08	
			NBR	1 40 50 10		1 50 50 10	
			TFM(PTFE)	1 40 50 05		1 50 50 05	
			TFM(PTFE)-PFA	1 40 50 00			
5.	Cylinder valves	4	PTFE	2 40 56 23		2 50 56 23	
	Ball valves	4	AISI 316	1 40 60 52		1 50 60 52	
			EPDM	1 40 60 08		1 50 60 08	
			NBR	1 40 60 10		1 50 60 10	
			PTFE	1 40 60 23		1 50 60 23	
			FPM (FKM)	1 40 60 09			
			PU	1 40 60 07		1 50 60 07	
7.*	a	In-/outlet sealing set	4	FEP/FKM core + FEP/FKM core	2 40 70 04		2 50 70 04
				EPDM + EPDM	2 40 70 08		2 50 70 08
				FKM + FKM	2 40 70 09		2 50 70 09
	b	In-/outlet sealing set	4	PTFE conductive + FKM	2 40 73 16		2 50 73 16
				PTFE conductive + EPDM	2 40 73 17		2 50 73 17
				NBR + NBR	2 40 70 10		2 50 70 10
9.	Housing bolt	8	AISI 304	2 40 042 50		2 50 042 50	
11.	Shock absorber	4	NR/St37	1 40 69 06		1 40 69 06	
12.	Nut with washer set	16	AISI 304	2 40 045 50		2 50 045 50	
13.**	Air valve, complete (thread mount)	1	PET-NBR	1 40 020 31			
			PET-FKM	1 40 020 32			
14.**	Diaphragm shaft	1	AISI 304	1 40 440 50		1 50 440 50	
15. ¹⁾	Air valve O-ring, external	6	NBR	1 40 080 10			
			FKM	1 40 080 09			
16.**	Central housing seal	2	PE	1 40 85 22		1 50 85 10	
17.**	Exhaust muffler, old version	1	PE porous	1 40 99 35		1 50 99 35	
			Bronze (sintered)	1 40 99 86		1 50 99 86	
	Exhaust muffler, actual version	1	PE porous	1 40 499 35		1 50 499 35	
			Bronze (sintered)	1 40 499 86 ⁽²⁾		1 50 499 86 ⁽²⁾	
18.**	Air adapter	1	PP	1 40 46 28			
			PE conductive	1 40 46 21 ⁽²⁾			
22.	Valve seat, old type	4	PE conductive	2 40 54 21		2 50 54 21	
			PTFE conductive		2 40 54 24		2 50 54 24
22a.	Valve seat, new type	4	PE conductive	2 40 654 21		2 50 654 21	
			PTFE conductive		2 40 654 24		2 50 654 24
24.	Plug lower	2	PE	2 40 59 21		2 50 59 21	
			PTFE		2 40 59 24		2 50 59 24
25.	Plug upper	2	PE	2 40 055 21		2 50 055 21	
			PTFE		2 40 055 24		2 50 055 23
26.	Valve stopper	2	PE	2 40 39 21		2 50 39 21	
			PTFE		2 40 39 24		2 50 39 24
27.	Bolt	2	PE	2 40 38 21		2 50 38 21	
			PTFE		2 40 38 24		2 50 38 24
28.***	Plug upper sealing	2	EPDM	2 40 78 08		2 50 78 08	
			FEP/FKM core	2 40 78 04		2 50 78 04	
			FEP/Silicone core	2 40 78 03			
			FKM	2 40 78 09		2 50 78 09	
			NBR	2 40 78 10		2 50 78 10	
30.**	Central housing O-ring	2	NBR	1 40 85 10		1 50 85 10	
35.	Central housing complete	1	Diverse	1 40 11 21		1 50 11 21	
70.	Pump housing plug set	1	PE	2 40 058 20		2 50 058 20	
82.	Shaft allen pin screw	2	AISI 304	1 40 540 50		1 50 540 50	
97.****	Valve seat key	1	Structural steel	2 40 254 47		2 50 254 47	
97a.****	Valve seat key cpl., new	1	Diverse	2 40 254C 00		2 50 254C 00	
98.****	Plug upper key	1	Diverse	2 40 758 00		2 50 758 00	
99.****	Plug lower key	1	Diverse	2 40 858 00		2 50 858 00	
100.****	Universal key	1	Structural steel	1 10 58 00			

* - in-/outlet standard sealing material execution: EPDM for EPDM diaphragms, NBR for NBR diaphragms, PTFE + EPDM for TFM(PTFE) and TFM(PTFE)-PFA diaphragms;

** - parts included in Item 35 „Central housing complete“;

*** - plug upper standard sealing O-rings material: EPDM for EPDM diaphragms, NBR for NBR diaphragms, FEP/Silicone (FEP encapsulated silicone core) for TFM(PTFE) and TFM(PTFE)-PFA diaphragms in DM 40/315 Pumps or FEP/FKM (FEP encapsulated FKM core) for TFM(PTFE) and TFM(PTFE)-PFA diaphragms in DM 50/565 Pumps;

**** - available on request (not delivered with the pump nor with spare part kit sets) ;

1) - included in Item 13 „Air valve, complete“, but also can be ordered separately;

2) - obligatory for “ATEX 0” (for detailed information, please refer to **Chapter 16.20**, page 82), but also can be ordered separately.

List of parts for spare part kits SET 1 and SET 2 in Plastic Series Pumps DM 40/315 R.. (Z..) with ATEX

Spare part kit set type	Item	Quantity	Part description	Pump size DM 40/315							
				Material execution ^{A)}							
				REE (ZEE)	RNN (ZNN)	RTT (ZTT)	RTF (ZTF)	RTS (ZTS)	RFT (ZFT)	RTU (ZTU)	
				Part number							
SET 2 (wet and dry side)	SET 1 (wet side)	4.	2	Diaphragm	1 40 50 08	1 40 50 10	1 40 50 05		1 40 50 00	1 40 50 05	
		5.	4	Valve ball	1 40 60 08	1 40 60 10	1 40 60 23		1 40 60 52	1 40 60 23	1 40 60 07
				Cylinder valve				2 40 56 23			
		7.	4	In-/outlet sealing	2 40 70 08	2 40 70 10	2 40 73 17				
		17.	1	Exhaust muffler	Actual (coarse thread) ^{B)}	1 40 499 35 or 1 40 499 86 ^{C)}					
	Old (fine thread)				1 40 99 35 or 1 40 99 86 ^{C)}						
	28.	2	Plug upper sealing	2 40 78 08	2 40 78 10	2 40 78 03					
	SET 2 (wet and dry side)	13.	1	Air valve, thread mount	1 40 020 31 or 1 40 020 32						
				Air valve, circlip mount ^{D)}	1 40 20 31 or 1 40 20 32						
		14.	1	Diaphragm shaft	1 40 440 50						
		16.	2	Central housing seal	1 40 85 22						
		22.	4	Valve seat, old type	2 40 54 21 (2 40 54 24)						
		22a.		Valve seat, new type ^{E)}	2 40 654 21 (2 40 654 24)						
		25.	2	Plug upper	2 40 055 21 (2 40 055 24)						
		26.	2	Valve stopper	2 40 39 21 (2 40 39 24)						
		27.	2	Valve stopper bolt	2 40 38 21 (2 40 38 21)						
		30.	2	Central housing O-ring	1 40 85 10						
		82.	2	Shaft allen pin screw	1 40 540 50						

- A) - typical pump material executions (other material executions may require different spare parts)
- B) - actual exhaust muffler with coarse thread (implemented gradually from 2018), part number 1 40 499 35 (PE porous) or 1 40 499 86 (sintered bronze)
- C) - exhaust muffler from sintered bronze is available only for "ATEX 0" (standard "ATEX" execution is PE porous muffler), or on customer's request;
- D) - circlip mounted air valve available for the pumps manufactured before August 2007 (pump's serial number verification required);
- E) - new type of valve seat (without notches) implemented gradually from January 2023 (pump part's visual verification required).

List of parts for spare part kits SET 1 and SET 2 in Plastic Series Pumps DM 50/565 R.. (Z..) with ATEX

Spare part kit set type	Item	Quantity	Part description	Pump size DM 50/565						
				Material execution ^{A)}						
				REE (ZEE)	RNN (ZNN)	RTT (ZTT)	RTF (ZTF)	RTS (ZTS)	RTU (ZTU)	
				Part number						
SET 2 (wet and dry side)	SET 1 (wet side)	4.	2	Diaphragm	1 50 50 08	1 50 50 10	1 50 50 05		1 50 50 00	1 50 50 05
		5.	4	Valve ball	1 50 60 08	1 50 60 10	1 50 60 23		1 50 60 52	1 50 60 07
				Cylinder valve				2 50 56 23		
		7.	4	In-/outlet sealing	2 50 70 08	2 50 70 10	2 50 73 17			
		17.	1	Exhaust muffler	Actual (coarse thread) ^{B)}	1 50 499 35 or 1 50 499 86 ^{C)}				
	Old (fine thread)				1 50 99 35 or 1 50 99 86 ^{C)}					
	28.	2	Plug upper sealing	2 50 78 08	2 50 78 10	2 50 78 04				
	SET 2 (wet and dry side)	13.	1	Air valve, thread mount	1 40 020 31 or 1 40 020 32					
				Air valve, circlip mount ^{D)}	1 40 20 31 or 1 40 20 32					
		14.	1	Diaphragm shaft, complete	1 50 440 50					
		16.	2	Central housing seal	1 50 85 22					
		22.	4	Valve seat, old type	2 50 54 21 (2 50 54 24)					
		22a.		Valve seat, new type ^{E)}	2 50 654 21 (2 50 654 24)					
		25.	2	Plug upper	2 50 055 21 (2 50 055 24)					
		26.	2	Valve stopper	2 50 39 21 (2 50 39 24)					
		27.	2	Valve stopper bolt	2 50 38 21 (2 50 38 24)					
		30.	2	Central housing O-ring	1 50 85 10					
		82.	2	Shaft allen pin screw	1 50 540 50					

- A) - typical pump material executions (other material executions may require different spare parts)
- B) - actual exhaust muffler with coarse thread (implemented gradually from 2018), part number 1 50 499 35 (PE porous) or 1 50 499 86 (sintered bronze)
- C) - exhaust muffler from sintered bronze is available only for "ATEX 0" (standard "ATEX" execution is PE porous muffler), or on customer's request;
- D) - circlip mounted air valve available for the pumps manufactured before August 2007 (pump's serial number verification required);
- E) - new type of valve seat (without notches) implemented gradually from October 2022 (pump part's visual verification required).

5.7. DM 80/850 P.., DM 80-850 T.. – exploded view

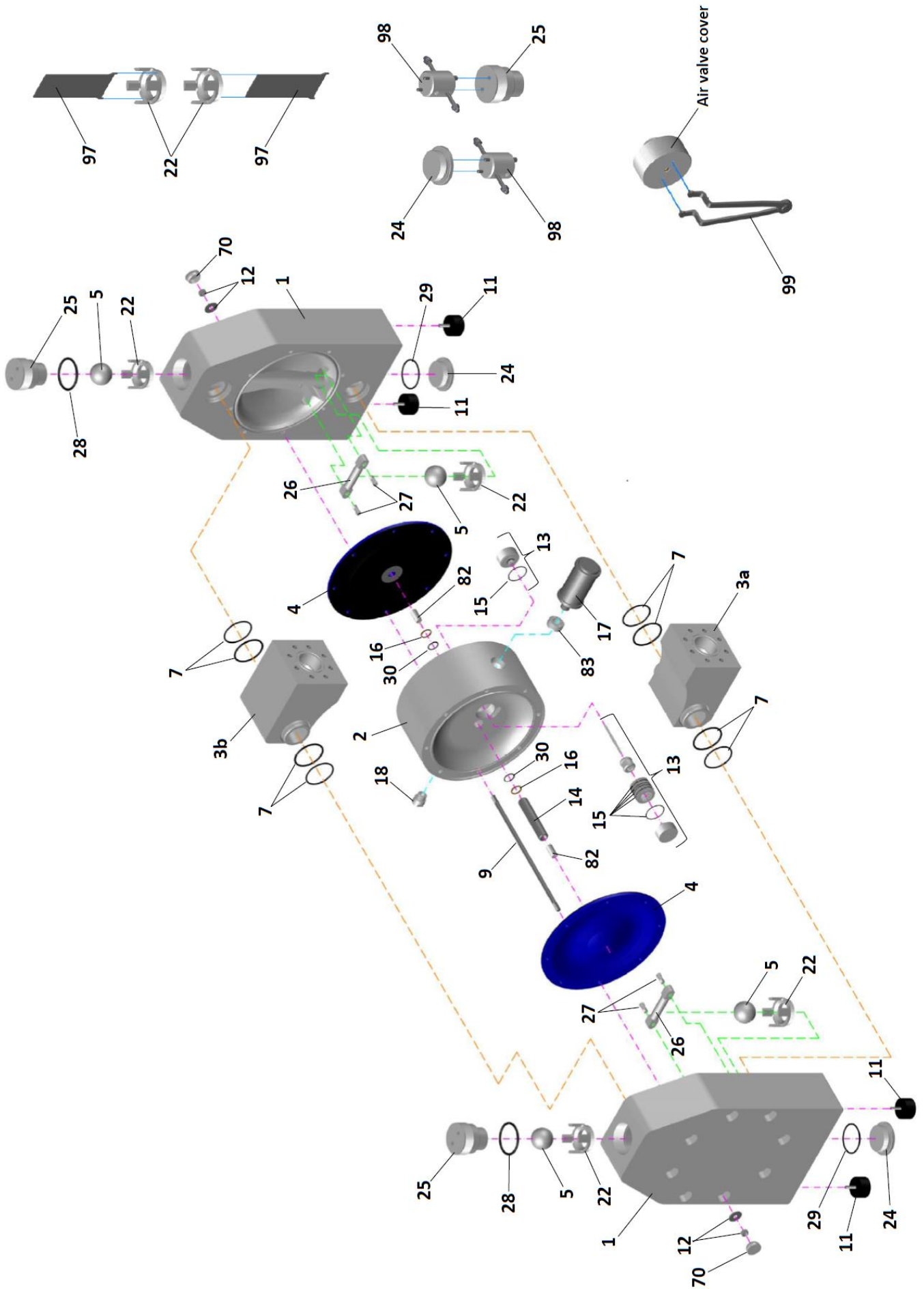

Spare parts list for DM 80/850 P., T.. Plastic Series Pumps

				Pump size and material execution (P-PE, T-PTFE)	
Item	Part name	Quantity	Material	DM 80/850 P..	DM 80/850 T..
1.	Pump housing	2	PE	2 80 01 20	
			PTFE		2 80 01 23
2.**	Central housing	1	PE	1 80 10 20	
3a.	Suction port	1	PE	2 80 26 20	
			PTFE		2 80 26 23
3b.	Discharge port	1	PE	2 80 25 20	
			PTFE		2 80 25 23
4.	Diaphragm	2	EPDM	1 80 50 08	
			NBR	1 80 50 10	
			TFM(PTFE)	1 80 50 05	
5.	Ball valves	4	EPDM	1 80 60 08	
			NBR	1 80 60 10	
			PTFE	1 80 60 23	
7.*	In-/outlet sealing, set	4	EPDM + EPDM	2 80 70 08	
			FEP/FKM core + FEP/FKM core	2 80 70 04	
			FKM + FKM	2 80 70 09	
			NBR + NBR	2 80 70 10	
9.	Housing bolt	8	AISI 304	2 80 042 50	
11.	Shock absorber	4	NR/St37	1 80 69 06	
12.	Nut with washer set	16	AISI 304	2 80 045 50	
13.**	Air valve, complete (thread mount)	1	PET-NBR	1 80 020 31	
			PET-FKM	1 80 020 32	
14.**	Diaphragm shaft	1	AISI 304	1 80 440 50	
15. ¹⁾	Air valve O-ring, external	6	NBR	1 80 080 10	
			FKM	1 80 080 09	
16.**	Central housing seal	2	PE	1 80 85 22	
17.**	Exhaust muffler	1	Diverse	1 80 99 00	
18.**	Air adapter	1	PP	1 80 46 28	
22.	Valve seat	4	PE	2 80 54 20	
			PTFE		2 80 54 23
24.	Plug lower	2	PE	2 80 59 20	
			PTFE		2 80 59 23
25.	Plug upper	2	PE	2 80 55 20	
			PTFE		2 80 55 23
26.	Valve stopper	2	PE	2 80 39 20	
			PTFE		2 80 39 23
27.	Bolt	4	PE	2 80 38 20	
			PTFE		2 80 38 23
28.***	Plug upper sealing	2	EPDM	2 80 78 08	
			FEP/FKM core	2 80 78 04	
			FKM	2 80 78 09	
			NBR	2 80 78 10	
29.***	Plug lower sealing	2	EPDM	2 80 478 08	
			FEP/FKM core	2 80 478 04	
			FKM	2 80 478 09	
			NBR	2 80 478 10	
30.**	Central housing O-ring	2	NBR	1 80 85 10	
35.	Central housing complete	1	Diverse	1 80 11 21	
70.	Pump housing plug set	1	PE	2 80 058 20	
82.	Shaft allen pin screw	2	AISI 304	1 80 540 50	
83.	Muffler adapter	1	PE	1 80 299 20	
97.****	Valve seat key	1	Structural steel	2 80 254 47	
98.****	Plug upper/lower key	1	Diverse	2 80 758 00	
99.****	Universal key	1	Structural steel	1 10 58 00	

* - in-/outlet standard sealing set material execution: EPDM+EPDM for EPDM diaphragms, NBR+NBR for NBR diaphragms, FEP-FKM+FEP-FKM for TFM(PTFE) diaphragms;

** - parts included in Item 35 „Central housing complete“;

*** - plug upper/lower standard sealing O-rings material: EPDM for EPDM diaphragms, NBR for NBR diaphragms, FEP/FKM (FEP encapsulated FKM core) for TFM(PTFE) diaphragms;

**** - available on request (not delivered with the pump nor with spare part kit sets);

¹⁾ - included in Item 13 „Air valve, complete“, but also can be ordered separately.

List of parts for spare part kits SET 1 and SET 2 in Plastic Series Pumps DM 80/850 P.. (T..)

Spare part kit set type	Item	Quantity	Part description	Pump size DM 80/850					
				Material execution ^{A)}					
				PEE (TEE)	PET (TET)	PNN (TNN)	PNT (TNT)	PTT (TTT)	
				Part number					
SET 2 (wet and dry side)	SET 1 (wet side)	4.	2	Diaphragm	1 80 50 08		1 80 50 10		1 80 50 05
		5.	4	Valve ball	1 80 60 08	1 80 60 23	1 80 60 10	1 80 60 23	1 80 60 23
		7.	4	In-/outlet sealing	2 80 70 08		2 80 70 10		2 80 70 04
		17.	1	Exhaust muffler	1 80 99 00				
		28.	2	Plug upper sealing	2 80 78 08		2 80 78 10		2 80 78 04
		29.	2	Plug lower sealing	2 80 478 08		2 80 478 10		2 80 478 04
	13.	1	Air valve, thread mount	1 80 020 31 or 1 80 020 32					
	14.	1	Diaphragm shaft	1 80 440 50					
	16.	2	Central housing seal	1 80 85 22					
	22.	4	Valve seat	2 80 54 20 (2 80 54 23)					
	25.	2	Plug upper	2 80 55 20 (2 80 55 23)					
	26.	2	Valve stopper	2 80 39 20 (2 80 39 23)					
	27.	4	Bolt	2 80 38 20 (2 80 38 23)					
	30.	2	Central housing O-ring	1 80 85 10					
	82.	2	Shaft allen pin screw	1 80 540 50					

^{A)} - typical pump material executions (other material executions may require different spare parts)

5.8. DM 80/850 R., DM 80-850 Z.. (ATEX) – exploded view

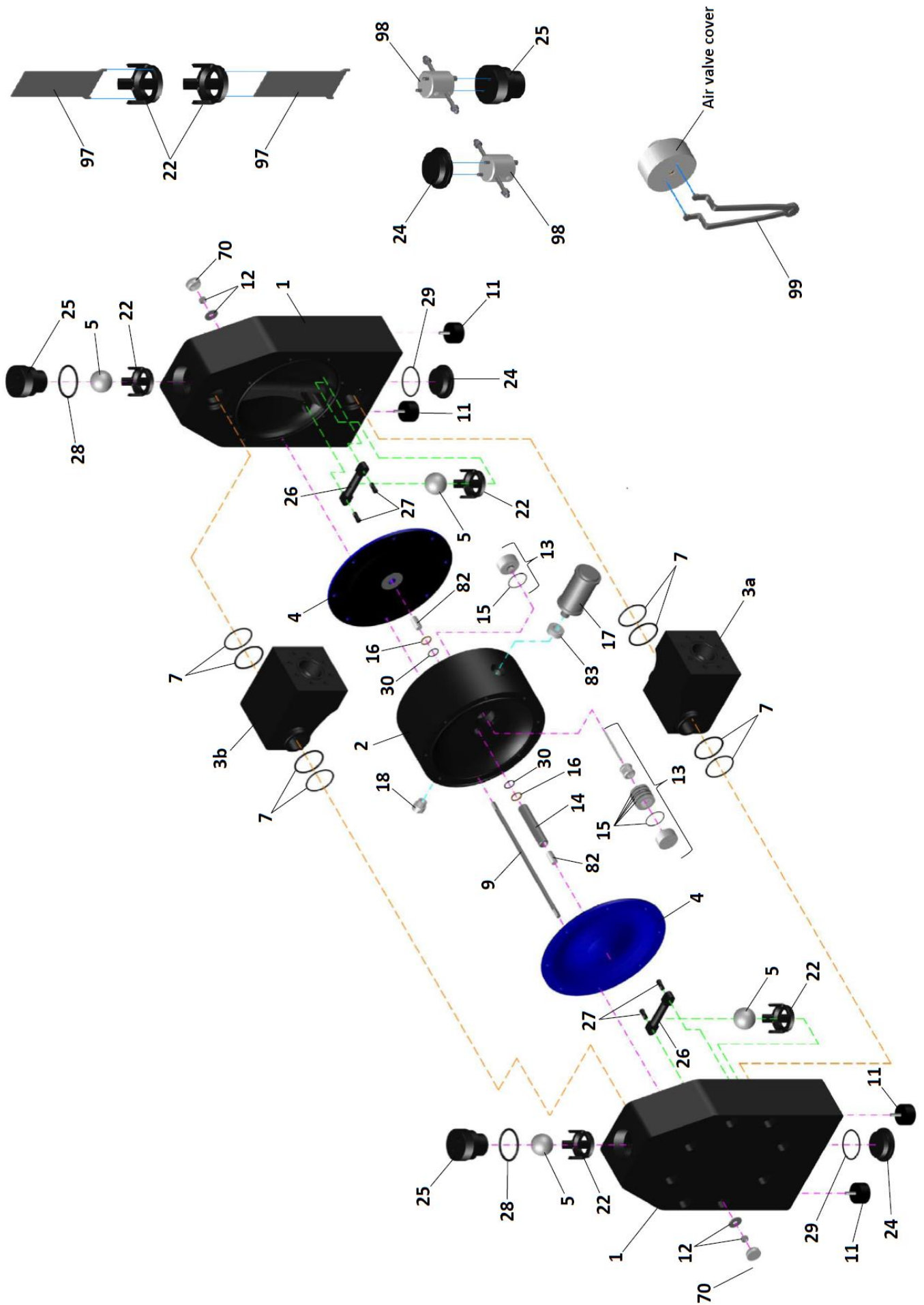

Spare parts list for DM 80/850 R.., Z.. Plastic Series Pumps (with ATEX)

				Pump size and material execution (R-PE c., Z-PTFE c.)	
Item	Part name	Quantity	Material	DM 80/850 R..	DM 80/850 Z..
1.	Pump housing	2	PE conductive	2 80 01 21	
			PTFE conductive		2 80 01 24
2.**	Central housing	1	PE conductive	1 80 10 21	
3a.	Suction port	1	PE conductive	2 80 26 21	
			PTFE		2 80 26 24
3b.	Discharge port	1	PE	2 80 25 21	
			PTFE		2 80 25 24
4.	Diaphragm	2	EPDM	1 80 50 08	
			NBR	1 80 50 10	
			TFM(PTFE)	1 80 50 05	
5.	Ball valves	4	EPDM	1 80 60 08	
			NBR	1 80 60 10	
			PTFE	1 80 60 23	
7.*	In-/outlet sealing, set	4	EPDM + EPDM	2 80 70 08	
			FEP/FKM core + FEP/FKM core	2 80 70 04	
			FKM + FKM	2 80 70 09	
			NBR + NBR	2 80 70 10	
9.	Housing bolt	8	AISI 304	2 80 042 50	
11.	Shock absorber	4	NR/St37	1 80 69 06	
12.	Nut with washer set	16	AISI 304	2 80 045 50	
13.**	Air valve, complete (thread mount)	1	PET-NBR	1 80 020 31	
			PET-FKM	1 80 020 32	
14.**	Diaphragm shaft	1	AISI 304	1 80 440 50	
15. ¹⁾	Air valve O-ring, external	6	NBR	1 80 080 10	
			FKM	1 80 080 09	
16.**	Central housing seal	2	PE	1 80 85 22	
17.**	Exhaust muffler	1	Diverse	1 80 99 00	
18.**	Air adapter	1	PP	1 80 46 28	
22.	Valve seat	4	PE conductive	2 80 54 21	
			PTFE conductive		2 80 54 24
24.	Plug lower	2	PE conductive	2 80 59 21	
			PTFE conductive		2 80 59 24
25.	Plug upper	2	PE conductive	2 80 55 21	
			PTFE conductive		2 80 55 24
26.	Valve stopper	2	PE conductive	2 80 39 21	
			PTFE conductive		2 80 39 24
27.	Bolt	4	PE conductive	2 80 38 21	
			PTFE conductive		2 80 38 24
28.***	Plug upper sealing	2	EPDM	2 80 78 08	
			FEP/FKM core	2 80 78 04	
			NBR	2 80 78 10	
29.***	Plug lower sealing	2	EPDM	2 80 478 08	
			FEP/FKM core	2 80 478 04	
			FKM	2 80 478 09	
			NBR	2 80 478 10	
30.**	Central housing O-ring	2	NBR	1 80 85 10	
35.	Central housing complete	1	Diverse	1 80 11 21	
70.	Pump housing plug set	1	PE	2 80 058 20	
82.	Shaft allen pin screw	2	AISI 304	1 80 540 50	
83.	Muffler adapter	1	PE conductive	1 80 299 21	
97.****	Valve seat key	1	Structural steel	2 80 254 47	
98.****	Plug upper/lower key	1	Diverse	2 40 758 00	
99.****	Universal key	1	Structural steel	1 10 58 00	

* - in-/outlet standard sealing set material execution: EPDM+EPDM for EPDM diaphragms, NBR+NBR for NBR diaphragms, FEP-FKM+FEP-FKM for TFM(PTFE) diaphragms;

** - parts included in Item 35 „Central housing complete“;

*** - plug upper/lower standard sealing O-rings material: EPDM for EPDM diaphragms, NBR for NBR diaphragms, FEP/FKM (FEP encapsulated FKM core) for TFM(PTFE) diaphragms;

**** - available on request (not delivered with the pump nor with spare part kit sets);

¹⁾ - included in Item 13 „Air valve, complete“, but also can be ordered separately.

List of parts for spare part kits SET 1 and SET 2 in Plastic Series Pumps DM 80/850 R.. (Z..) with ATEX

Spare part kit set type		Item	Quantity	Part description	Pump size 80/850				
					Material execution ^{A)}				
					REE (ZEE)	RET (ZET)	RNN (ZNN)	RNT (ZNT)	RTT (ZTT)
					Part number				
SET 2 (wet and dry side)	SET 1 (wet side)	4.	2	Diaphragm	1 80 50 08		1 80 50 10		1 80 50 05
		5.	4	Valve ball	1 80 60 08	1 80 60 23	1 80 60 10	1 80 60 23	1 80 60 23
		7.	4	In-/outlet sealing	2 80 70 08		2 80 70 10		2 80 70 04
		17.	1	Exhaust muffler	1 80 99 00				
		28.	2	Plug upper sealing	2 80 78 08		2 80 78 10		2 80 78 04
		28.	2	Plug lower sealing	2 80 478 08		2 80 478 10		2 80 478 04
			13.	1	Air valve, thread mount	1 80 020 31 or 1 80 020 32			
			14.	1	Diaphragm shaft	1 80 440 50			
			16.	2	Central housing seal	1 80 85 22			
			22.	4	Valve seat	2 80 54 21 (2 80 54 24)			
			25.	2	Plug upper	2 80 55 21 (2 80 55 24)			
			26.	2	Valve stopper	2 80 39 21 (2 80 39 24)			
			27.	2	Bolt	2 80 38 21 (2 80 38 24)			
			30.	2	Central housing O-ring	1 50 85 10			
			82.	2	Shaft allen pin screw	1 80 540 50			

^{A)} - typical pump material executions (other material executions may require different spare parts)

6. Assembly



CAUTION

- ! When installing accessories prevent any foreign matter from getting into the product. Otherwise malfunction of the air-valve may follow.

7. Installation

7.1. Installing the pump

- 1) Decide where the pump is to be installed and secure a site.

Note:

- The suction lift should be kept as short as possible.
- Sufficient space around the pump for maintenance must be provided.

When fixing the pump in place, use the cushions on the pump base. The tied-down bolts should be tightened a little at a time to secure the pump.

SELF PRIMING APPLICATION

Suction lift capability may vary depending on the construction materials and application parameters. The range is from 0.5-5 meters (depends on the pump size) dry to 9 meters in a primed condition (values calculated for pumping water at 20 degrees Celsius).

SUBMERGED OPERATION

All pumps may operate in full submersion. Construction materials must be compatible with surrounding liquid and the air exhaust must be placed above the liquid level.

POSITIVE SUCTION HEAD

Common as a method of drawing off the bottoms of holding tanks and clarifiers. Optimum inlet pressure should be kept at 0.2-0.3 bar.

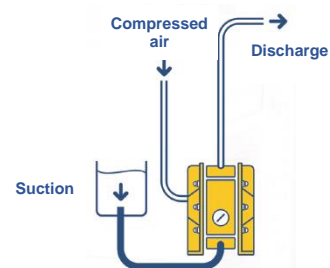
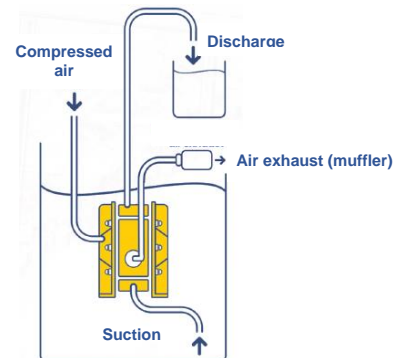
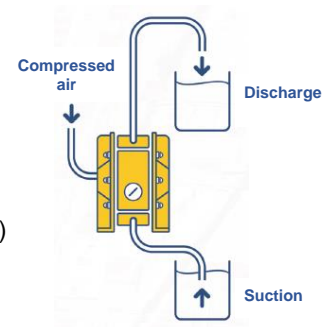



CAUTION

- ! Vibration generated by pump operation should be absorbed. Take it into consideration when mounting it.
- ! When using the pump in submerged position, follow the steps below:
 - Verify the corrosion resistance of each component of the pump. DO NOT expose the pump to any fluid for which it does not have proper corrosion resistance.
 - Exhaust should direct outside, not into the fluid in which the pump is submerged.
- ! The running pump may generate noise. Its level will depend upon conditions of use (kind of fluid being pumped, supply air pressure and discharge pressure).



WARNING

- ! The end of the hose must be equipped with a pit, a protection box, etc. at the end of the hose in case the diaphragm gets damaged and a leakage of the fluid follows.
- ! Pump exhaust should be directed to a safe place, away from people, animals and food.

Size	DM 08/10	DM 10/25	DM 15/55	DM 25/125	DM 40/315	DM 50/565	DM 80/850
Max number of strokes/min. at nominal performance	500	430	240	160	140	100	100



CAUTION

- ! Before putting the pump into operation as well as after some hours of pumping, all housing bolts [9] have to be fixed according to the torque data of the following schedule, as the elements of construction "settle". Both lower and upper plugs [24, 25] have to be fixed, too. Fixing all these parts is necessary as well after longer periods of stoppage, at extreme temperature variations, after transport and dismantling the pump.

Size	DM 08/10	DM 10/25	DM 15/55	DM 25/125	DM 40/315	DM 50/565	DM 80/850
Torque values for housing bolts (Nm): PE pumps	3	5	8	13	17	22	24
PTFE pumps	2	4	7	11	15	19	21

7.2. Connecting the ground wire

- a) When installing the conductive pump, be sure to connect the ground wire at the specified position.
- b) Ground wires should be connected to peripheral equipment and piping as well.
- c) Use 2.0 mm² minimum ground wire.



WARNING



Ground wires must be connected to the piping and any other peripheral equipment. When operating the pump make sure it is properly grounded. Otherwise friction between the parts and abrasion caused by some fluids flowing inside the casing may generate static electricity. In addition it may cause fire or electric shock, depending on the type of fluid being pumped and the installation environment (such as gases in the air or the surrounding mixtures).

8. Connection

8.1. Connecting fluid piping

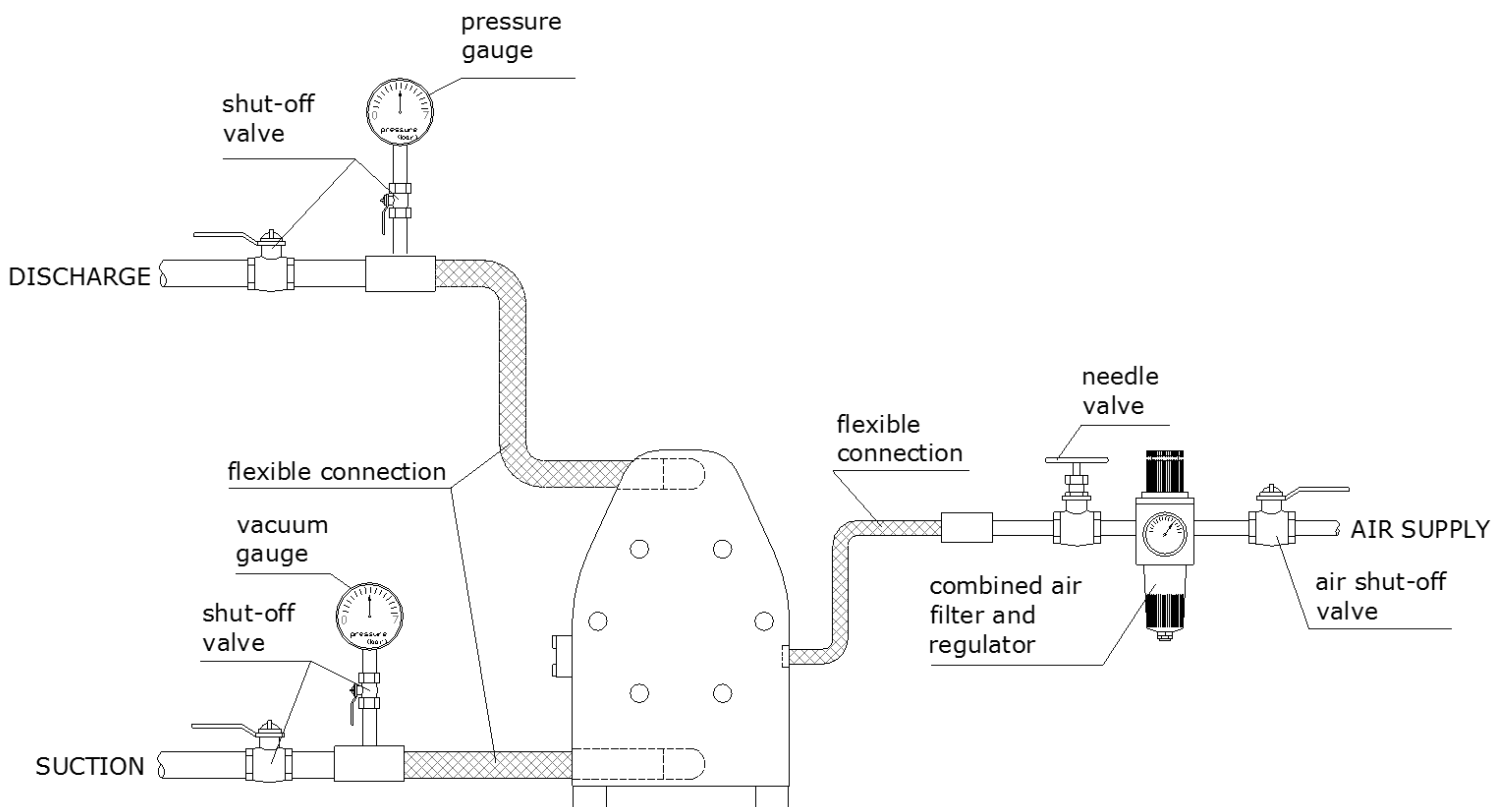

- 1) Connect a flow valve and a drain valve to the fluid discharge port of the pump.
- 2) Connect a valve for maintenance to the fluid suction intake port of the pump.
- 3) Connect a hose to the valve on the suction-port side and the valve of the discharge-port side of the pump.
- 4) Connect a hose on the suction-side intake and the discharge-port side to the respective vessels.



CAUTION

- ! A hose must be flexible to absorb pump vibration. The hose must be grounded.
- ! There must be NO external force on any connection part of the pump. Be especially careful not to have the pump support part of the weight of the hose and the piping.
- ! Use a sturdy hose that will not collapse under the strong suction of the pump. The hose must be of more than sufficient pressure rating.
- ! Use a hose of a diameter the same as or larger than the pump's ports. If the diameter of a hose is smaller, it will affect the pump's performance or cause its malfunction.
- ! Keep a vessel below the relief valve to catch any drain off.
- ! The product has been inspected using clean water at 8 bar discharge pressure.

8.2. Connecting air piping



WARNING

- ! Before starting work, make sure that the air compressor is shut off.

- 1) Connect an air valve, air filter, regulator to a hose connected to the compressor. Install items near the pump.
- 2) Connect the hose from the peripheral equipment to the air valve of the pump's supply port.

Note:

The diameter of the piping should be the same as the diameter of the pump supply port in order to supply sufficient air. Peripheral equipment with sufficient airflow should be chosen to meet the requirement of the pump air consumption. It must be installed nearest the pump unit, even using dry air. Usage and stability of air pressure must be considered.

9. Operation

9.1. Method of operation



CAUTION

- ! Before starting the pump, check that all piping is properly connected.
- ! Before starting the pump, check that **all the bolts are securely tightened**.
- ! Check that the regulator and the drain valve on the discharge side are closed and that the valve on the suction side is opened.

- 1) Start the air compressor.
- 2) Open the air valve. Using a regulator adjust the supply air pressure to within the permissible range.
- 3) Open the flow valve on the discharge side.
- 4) First, check that fluid is flowing inside the piping and is being pumped to the discharge side, and then fully open the air valve.



CAUTION

- ∅ Do NOT open the air valve suddenly.

9.2. Flow adjustment

Adjust the flow valve on the discharge side, or adjust the supply air pressure.



CAUTION

- ! The supply air pressure may initially rise during closing the flow valve. Make sure that the pressure is kept within the normal operating range.
- ! The permissible suction flow speed can vary depending upon the viscosity and specific gravity of the fluid, the suction stroke and other factors. However in case of a rapid growth of the pump speed (flow speed of fluid), cavitation will occur. This will reduce pump performance and may cause a malfunction. In order to prevent cavitation, adjust the supply air pressure and the flow.
- ! If fluid is not discharged after you start the pump, or if you hear an abnormal noise or notice any irregularity, shut down the pump immediately.

9.3. Shutdown

Close the air valve of the pump and shut off the supply air. **DO NOT** stop the pump by closing the discharge valve while the compressed air is still supplied to the pump.



CAUTION



When the pump is shut down while pumping slurry, particulate matter contained in the slurry will be deposited and get stuck inside the out chamber. Therefore after finishing work the pump must be purged of the remaining fluid. Otherwise when starting the pump again, the diaphragm may get damaged and the diaphragm shaft rod may bend.



CAUTION



Keep a vessel below the relief valve for any drain off.



Be careful! - Fluid under pressure will gush out the moment you open the valve.



If the pump is unused for a prolonged period, purge and clean it.

10. Method of cleaning



WARNING



Make sure that compressed air is not supplied to the pump **BEFORE** you start cleaning the pump.



Make sure that the pump is not pressurized **BEFORE** you start cleaning the pump.

- 1) Remove the hose from the suction side of the pump.
- 2) Close the flow valve on the discharge side and open the drain valve. Then start air pressure for a while to discharge possibly much fluid remaining inside the pump.
- 3) Remove the hose from the discharge side, and attach different hoses to the suction side and the discharge side for cleaning.
- 4) Be ready with a vessel with cleaning solution, the kind appropriate for the type of fluid pumped. Next connect the suction-side and the discharge-side hoses of the pump.
- 5) Start the pump air pressure slowly, and let the cleaning solution circulate for sufficient cleaning.
- 6) Flush with clean water.
- 7) Remove the hose from the suction side of the pump, run the pump for a while to purge the pump of remaining fluid as much as possible.



CAUTION

- ! Be extremely careful when removing piping - the fluid will gush out.
- ! After cleaning with clean water, turn the pump upside-down to let the water flow out.

11. Daily check

Before starting pump operation, conduct the following check procedures every day. In case there appears any irregularity, do NOT start running the pump until the cause of the irregularity has been determined and corrective measures have been taken.

- a) Make sure that there is no leakage of fluid from any connection part or the pump.
- b) Make sure that there are no cracks in the pump casing or piping.
- c) Check the tightness of every bolt of the pump.
- d) Make sure that the connection parts of the piping and peripheral equipment are not loose.
- e) Be sure that any pump parts to be replaced at regular intervals have been changed.

12. Possible problems

12.1. Pump does not run

Cause	Action to take
The exhaust port (muffler) of pump is clogged with sludge.	Check and clean the exhaust port and replace muffler.
Air is not supplied.	Start the compressor, and open the air valve and air regulator.
The supply air pressure is low.	Check the compressor and the configuration of air piping.
Air leaks from connection parts.	Check the connection parts and tightness of bolts.
The flow valve on the discharge side is not open.	Open the flow valve on the discharge side.
The fluid piping is clogged with sludge.	Check and clean the fluid piping.
The pump is clogged with sludge.	Disassemble the casing, check and clean.

12.2. Pump runs, but fluid does not come out

Cause	Action to take
The suction lift or discharge head is long.	Confirm the piping configuration and shorten the length.
The discharge-side fluid piping (including the strainer) is clogged with sludge.	Check and clean the fluid piping.
The valve on the suction side is not open.	Open the valve on the suction side.
The pump is clogged with sludge.	Disassemble the casing, check and clean.
The balls and valve seats are worn out or damaged.	Disassemble the pump, check and replace parts.

12.3. Flow (discharge volume) decreased

Cause	Action to take
The supply air pressure is low.	Check the compressor and configuration of air piping.
Air piping or peripheral equipment is clogged with sludge.	Check and clean the air piping.
The discharge-side flow valve opens differently.	Adjust the discharge-side flow valve.
Air is taken in together with fluid.	Replenish fluid and check the configuration of the suction-side piping.
Cavitation occur.	Adjust the supply air pressure and discharge pressure, and shorten the suction lift.
Chattering occurs.	Adjust the supply air pressure and discharge pressure. Reduce inlet flow valve to adjusting liquid pressure and volume.
The fluid piping (including the strainer) is clogged with sludge.	Check and clean the fluid piping and strainer.
The exhaust port (muffler) of the pump is clogged with sludge.	Check and clean the exhaust port and muffler.
The pump is clogged with sludge.	Disassemble the casing, check and clean.

12.4. Liquid leakage from exhaust port (silencer)

Cause	Action to take
Damaged diaphragms.	Replace the diaphragms.

12.5. High air consumption during operation

Cause	Action to take
The air valve O-rings and sleeves are worn out.	Disassemble the air-valve, check and clean. Replace parts as necessary.

12.6. Irregular noise

Cause	Action to take
The supply air pressure too high.	Adjust the supply air pressure.
The pump is clogged with sludge with particles of larger than the permissible diameter.	Disassemble the casing, check and clean.

12.7. Irregular vibration

Cause	Action to take
The supply air pressure too high.	Adjust the supply air pressure.
The sleeves are worn out.	Disassemble the air-valve, check and clean. Replace parts as necessary.
Connection parts and pump mounting are loose.	Check each connection part and tighten the bolts.

If any of the above mentioned causes do not apply to your problem, contact your dealer or our office.

13. Pump storage

Usually each DELLMECO pump is delivered packaged, but after unpacking it is ready for operation. If the pump unit is not to be installed right after delivery, proper storage conditions have to be ensured for a later trouble-free operating. The pump has to be protected from wetness, coldness, heat, dirtying, UV-radiation (especially PE Pumps) and mechanical influences.

Recommended storage conditions are as follows:

- Steady ventilated storage room, free of dust and vibration
- Ambient temperature between 15°C (59°F) and 25°C (77°F)
- Relative humidity below 65%
- Protection against direct thermal influences (sun, heating).

14. Returning the product for servicing

If you want to return the product for servicing, copy the **Trouble-Reporting Datasheet** (page 40), fill it out giving the details of the problem and conditions of operation, scan it and send via e-mail to your dealer or our regional office. When you get an acceptance from your dealer or regional office:

- 1) Clean the pump.
- 2) Return the product in the same package as when it was first shipped from the factory.

Trouble-Reporting Datasheet

Your information will be most helpful in our efforts to improve our service as well as checking into causes of troubles and irregularities. We kindly request you therefore to fill out the following datasheet carefully, scan it and e-mail it to your dealer or our regional office. Thank you.

Company	Name of person in charge
Address	Department
	Telephone
	E-mail address
MODEL	Year of manufacturing
Period of use	Serial No.
Operating conditions *Indoor * Outdoor	Date of Purchase
Frequency of operation * Continuous * Intermittent _____ Hours/day/week/month	Name of Dealer _____ Type of fluid pumped _____
Operating air pressure _____ bar Discharge pressure _____ bar Discharge volume _____ l/min. Suction side _____ m Suction side diameter _____ m Discharge side _____ m	Specific gravity _____ Viscosity _____ cP Fluid temperature _____ *C/*F Slurry: *YES Density _____ wt% Particulate diameter _____ mm *NO
Problem	
Draw a summary drawing of application, including size, length of piping, and component parts (if more space for a drawing/sketch is required, please do it on the reverse side of this document, or send e-mail it as a separate file in one of the following formats: png, jpg, pdf)	



WARNING



It is the end-user responsibility to thoroughly wash and clean the pump to prevent any damages caused by accidental liquid leaks.



CAUTION



Be sure to maintain the transport safety by preventing any liquid leaks from the pump.

14. Main body specification

14.1. Main specification



CAUTION



Due to constant improvements and/or modifications to our products, the dimensions and detailed technical specifications may be changed without prior information. Any claims concerning these changes shall not be considered. Please contact your dealer or our regional office for details.

14.2. Appearance and dimensions

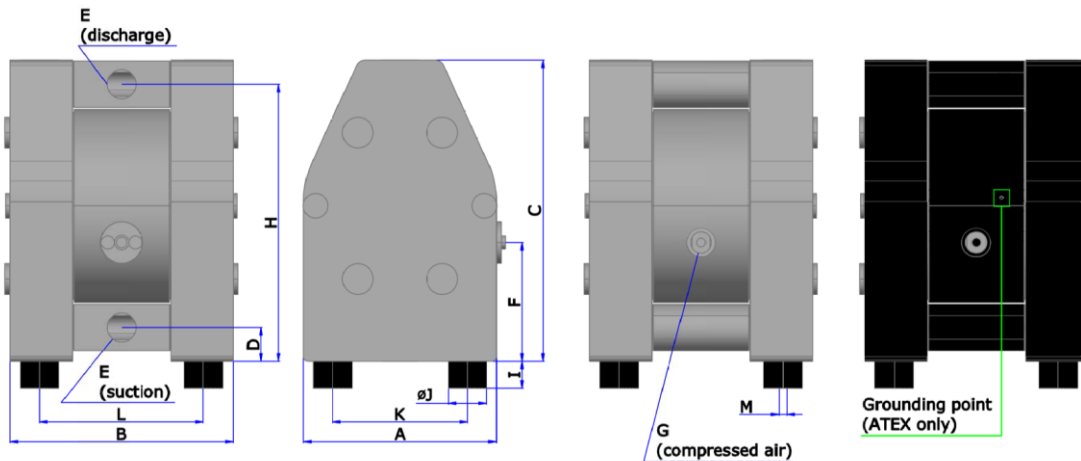

Pump size	A	B	C	D	E	F	G	H	I	ØJ	K	L	M
DM 08/10	70	113	120	15	G 1/4"	58	R 1/8"	107	10	15	50	86	M4
DM 10/25	105	128	164	18	G 3/8"	84	R 1/8"	150	10	15	75	93	
DM 15/55	153	177	235	25	G 1/2"	87	R 1/4"	217	18	30	112	136	M8
DM 25/125	200	232	312	35	G 1"	123	R 1/4"	287	28	40	140	170	
DM 40/315	270	312	426	42	G 1 1/2"	109	R 1/2"	388	30	60	190	227	
DM 50/565	350	385	540	45	G 2"	158	R 1/2"	485	30	60	280	282	M12
DM 80/850	480	580	800	100	DN80 DIN/PN16 (incl. G 3")	388	R 3/4"	690	40	75	395	495	

CAUTION: Dimensions for the Plastic Series Pumps with ATEX are identical with the above. Grounding point (M4 internal threaded hole) is located on the central housing, right and up to the compressed air inlet connection ("G" symbol), as shown on the above drawing (first picture from the right).

14.3. Technical Data

Pump size	08/10	10/25	15/55	25/125	40/315	50/565	80/850
Max. capacity [l/min.]	10	25	55	125	315	565	850
Max. pressure [bar g]	8						
Nominal port size [in.]	G ¼"	G ⅜"	G ½"	G 1"	G 1 ½"	G 2"	DN80 DIN/PN16 (incl. G 3")
Air connection [in.]	R ⅛"		R ¼"		R ½"		R ¾"
Max. suction lift dry* [MWC]	0.5/1.5 ^{A)}	2.0	3.0	4.0		5.0	
Max. suction lift wet [MWC]	8.0						
Max. size of solids [mm]	2.0	3.0	4.0	7.0	10.0	12.0	15.0
Temperature limits – PE, PE c. [°C]	70						
Temperature limits – PTFE, PTFE c. [°C]	100**			110**			
Weight – PE, PE c. [kg]	0.9	1.6	4.2	10	24	45	170
Weight – PTFE, PTFE c. [kg]	1.5	2.4	7	16.5	45	87	340
Material of pump wetted parts	PE, PE conductive, PTFE, PTFE conductive						
Diaphragm material options	TFM, TFM-PFA	EPDM, NBR, TFM, TFM-PFA				EPDM, NBR, TFM	
Valve balls material options	AISI 316, PTFE	AISI 316, EPDM, FKM, NBR, PTFE, PU***				EPDM, NBR, PTFE	
Cylinder valves material options	PE, PTFE						
O-rings material options	FEP-Silicone ^{B)} , FEP-FKM, FKM	EPDM, FEP-Silicone ^{B)} , FEP-FKM, FKM, NBR, PTFE + EPDM, PTFE + FKM, PTFE c.+ EPDM, PTFE c. + FKM				EPDM, NBR, FEP-FKM	

^{A)} – suction lift dry 0.5 m for ball valves and 1.5 m for cylinder valves

^{B)} – FEP-Silicone (FEP encapsulated silicone) O-rings available for specific pump sizes

* – real dry suction lift values can be smaller from the stated maximum values, due to: pump's execution material, liquid properties (specific gravity, dynamic viscosity), suction hose inside diameter, etc.

** – only for TFM(PTFE) and/or TFM(PTFE)-PFA diaphragms (for the other diaphragms: EPDM or NBR – maximum up to 70°C)

*** – PU (polyurethane) ball valves available from DM 15/55 to DM 50/565 pump sizes

14.4. Pump code

DM 15/55 PTS-DM 1	DM 1 - Optional equipment:
<p>DM – DELLMECO Pump</p> <p>15 – ½" BSPP port dimension</p> <p>55 – max capacity l/min at 8 bar air supply pressure</p> <p>P – Housing material:</p> <p>P – PE</p> <p>R – PE conductive (ATEX)</p> <p>T – PTFE</p> <p>Z – PTFE conductive (ATEX)</p> <p>T – Diaphragm material:</p> <p>E – EPDM</p> <p>F – TFM/PTFE/PFA</p> <p>N – NBR</p> <p>T – TFM/PTFE</p> <p>S - Material and kind of valve:</p> <p>E - EPDM, ball valve</p> <p>N - NBR, ball valve</p> <p>S - AISI 316, ball valve</p> <p>T - PTFE, ball valve</p> <p>U - Polyurethane, ball valve</p> <p>F - PTFE, cylinder valve</p> <p>P - PE, cylinder valve</p> <p>C - Ceramic, ball valve</p>	<p>BC1 – Barrier Chamber with sensors (NAMUR)</p> <p>BC2 – Barrier Chamber as BC1 with controllers</p> <p>BC3 – Barrier Chamber as BC2, ATEX</p> <p>SC1 – Stroke sensor, ATEX</p> <p>SC2 – SC1 plus stroke counter</p> <p>SC3 – SC1 plus stroke counter – ATEX</p> <p>SC5 – Stroke counting pneumatical with pressure transmitter</p> <p>SC6 – SC5 plus stroke counter</p> <p>DM1 – Diaphragm Monitoring, NAMUR – ATEX</p> <p>DM2 – Diaphragm Monitoring with controller</p> <p>F1 – Flange Connection PN10 with EPDM O-ring</p> <p>F2 – Flange Connection PN10 with NBR O-ring</p> <p>F3 – Flange Connection PN10 with FEP/FKM O-ring</p> <p>F4 – Flange Connection JIS 5K</p> <p>F7 – Flange Connection PN10 DIN 2576</p> <p>F8 – Flange Connection ANSI 150 RF-SO</p> <p>F9 – Flange Connection PN16 DIN 2277/2278</p> <p>NPT – NPT thread connection (female)</p> <p>BSPT – BSPT thread connection (female)</p> <p>BF1 – Back flushing system, hand operated, EPDM seals</p> <p>BF2 – Back flushing system, hand operated, FEP/FKM seals</p> <p>BF4 – Back flushing system, pneumatical, EPDM seals</p> <p>BF5 – Back flushing system, pneumatical, FEP/FKM seals</p> <p>AF1, AF2 – Air filter, regulator, valve, nipple, connector</p> <p>D – Drum pump</p> <p>HP – High pressure</p> <p>MV – Pump with solenoid valve</p> <p>S – Sleeve with split connections</p> <p>SSC – Pump with AISI 316 inlet/outlet connections</p> <p>P – Powder pump</p> <p>T – Trolley</p> <p>CLEAN – The clean package to meet enlarged purity requirements for special pump applications</p>

14.5. Performance curves

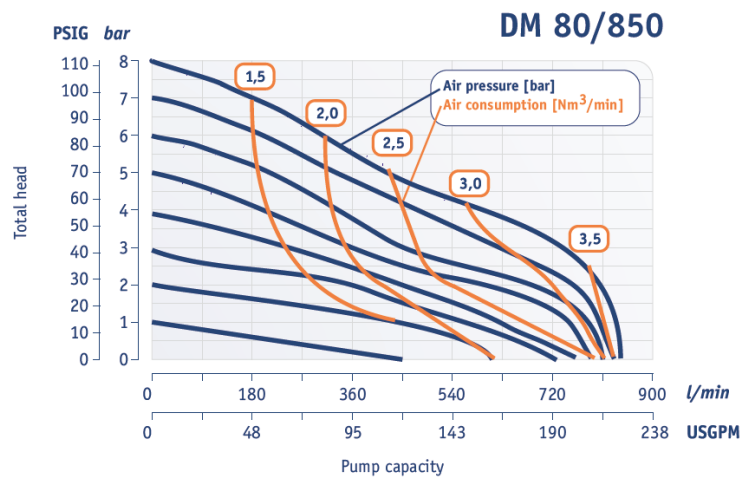
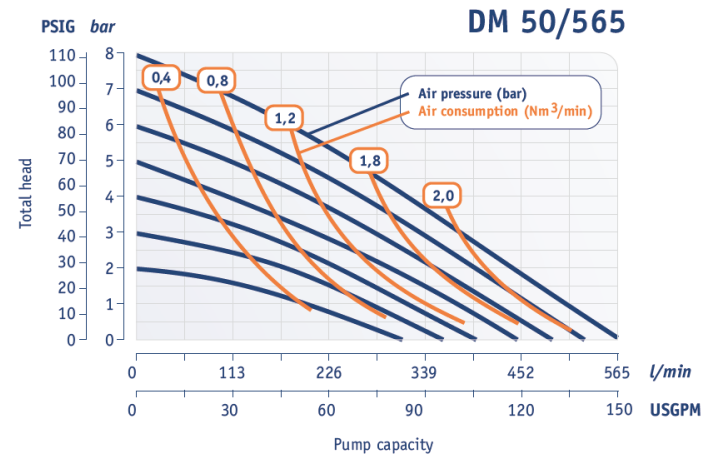
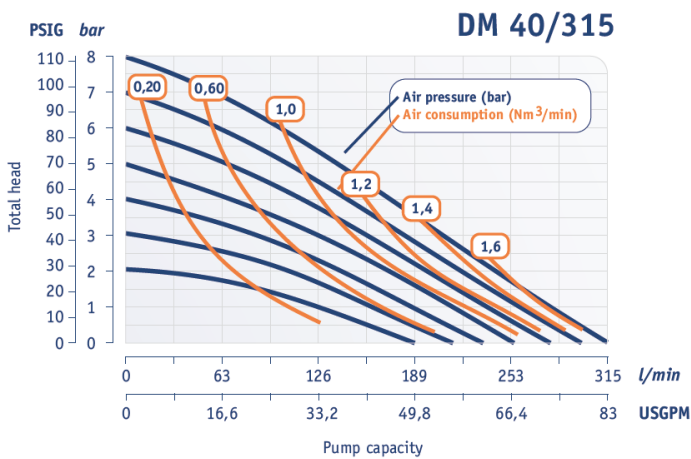
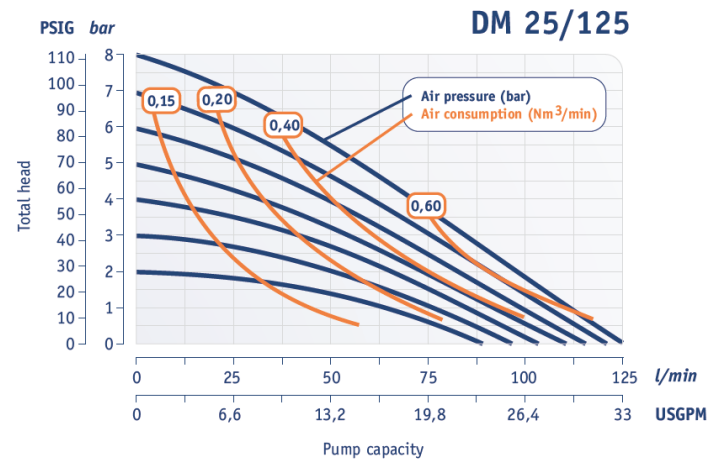
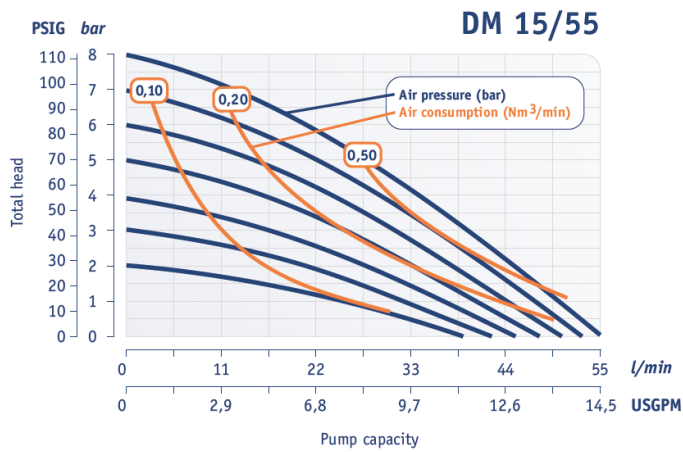
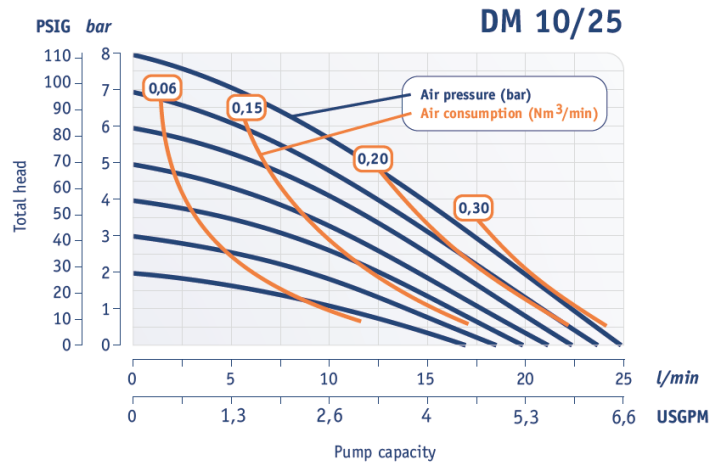
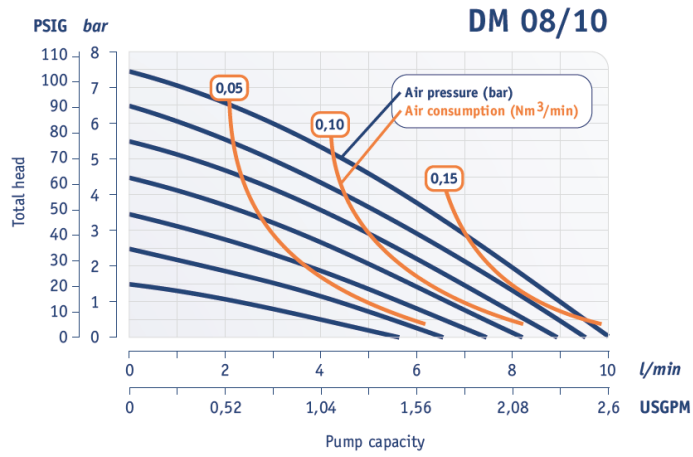

15. Dellmecco Active Pulsation Dampeners for Plastic Pumps

15.1. Main specification

The DELLMECO Plastic Series pulsation dampeners represent the latest generation of active pulsation dampeners. They are specially designed to be used along with DELLMECO pneumatic double diaphragm pumps of the Plastic range. A general aspect to be considered is that a pulsation dampener slightly decreases total capacity of the system (depending on the point of operation).

Before putting a DELLMECO pulsation dampener into operation make sure, that the materials of construction are resistant to the chemicals to be pumped. To check this, the appropriate pulsation dampener code is required. This code, as well as the serial number, can be found in the following. Besides, these data are noted on the identification plates on the dampener itself.

Example of the damper type code:

DM	15	P	E	P	
					<u>Material of dampener head:</u>
					P - PE
					R - PE conductive
					<u>Diaphragm material:</u>
					E - EPDM
					F - TFM-PFA
					N - NBR
					T - TFM(PTFE)
					<u>Material of dampener housing:</u>
					P - PE
					R - PE conductive (ATEX)
					T - PTFE
					Z - PTFE conductive
					<u>Size, nominal connection size:</u> 08: G 3/8", 10-15: G 1/2", 25: G 1", 40: G 1 1/2", 50: G 2", 80: G 3"

DELLMECO Active Pulsation Dampener

Air supply connection: DM 08-25: R 1/8", DM 40-50: R 1/4" , DM 80: R 3/4"

Max. operating pressure: 7 bar g

Max. operating temperature: for dampener housing in PE and PE conductive: 70°C ,
for dampener housing in PTFE and PTFE conductive:

DM 08 – DM 10 sizes: 100°C
DM 15 – DM 80 sizes: 110°C

For inflammable liquids as well as for applications in explosion protected areas, only dampeners made of conductive polymer materials (codes R and Z) may be used. It is not necessary to ground the dampener separately, as the dampener is connected conductively to the pump, which is conductive and has to be grounded itself.

In general, pump and dampener are dispatched completely mounted. Still, they can be packed in separate boxes, for client's wish. If so, the dampener has to be screwed into the thread at the top of discharge port carefully, but only until the dampener is in contact with the pump. Exceeded tightening may damage the thread. Besides, a correct positioning of the O-ring [45] within the groove has to be ensured.

The DELLMECO dampener can easily be attached to a pump at any time in the future by changing the discharge port. The use of a pulsation dampener of the series DM reduces the capacity of the complete system in dependence of the point of operation.

Before connecting the pump, take the yellow blind plugs out of air inlet which is located on the top of the dampener head [41]. For correct operation, the dampener absolutely needs an air-supply of its own, which has to be taken from the air-supply of the pump. Pump and pulsation dampener have to be connected to the same air pressure. No stop or regulating valve may be placed between pump and dampener. The driving air has to be oil-free, dry and clean. Together with the pump an empty dampener has to be driven slowly. The dampeners are self-regulating for all changing operating conditions.

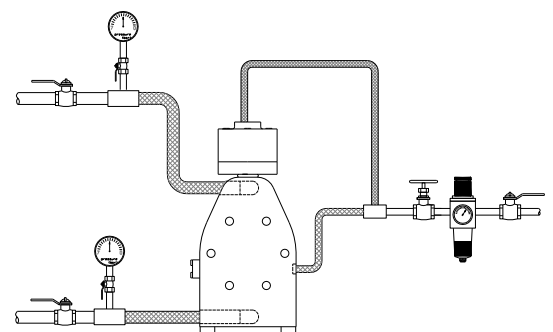



CAUTION

- ! Before putting the pulsation dampener into operation as well as after some hours of operating, the housing bolts [42] have to be tightened carefully, as the elements of construction tend to "settle". Fixing the bolts is necessary as well after longer periods of stoppage, at extreme temperature variations, transport and after dismantling. Torque value for each size and material execution of the Plastic Series Pulsation Dampener is specified below.
- ! Pressure tests of the plant, the pump and the dampener are included and may only be carried out with the aggregate (pump and dampener) disconnected from the pressure on both ports or by using the pressure the aggregate develops while operating. The load of a pressure in the plant may damage the pump and the pulsation dampener.
- ! Before starting to disassemble the pump, take care that pump and dampener have been emptied and rinsed. Further, both have to be cut off from any energy on the air and product side. If pump and dampener are being deported from the plant, a reference about the delivered liquid has to be attached.
- ! Please respect the relevant additional security advices, if the pump and the dampener have been used for aggressive, dangerous or toxic liquids.
- ! Before putting the pump and the dampener back into operation, the tightness of both has to be checked.

Recommended tightening torque for the pulsation dampener housing bolts are presented in the below chart:

Torque values for the pulsation dampener housing bolts (Nm):							
Material execution	Pulsation Dampener size						
	DM 08	DM 10	DM 15	DM 25	DM 40	DM 50	DM 80
PEP, PNP, PTP	3*	4	4	6	10	16	20
RER, RNR, RTR							
TEP, TNP, TTP	2**	3	3	5	8	14	17
ZER, ZNR, ZTR							

* - only for DM 08 PTP and DM 08 RTR

** - only for DM 08 TTP and DM 08 ZTR

Disassembly instructions

Remove the plugs [46] and unscrew the nuts [43] from the housing bolts [42] carefully. After that, all the parts can be removed. Screw the diaphragm [40] off the actuator shaft [39]. A re-assembly of used piston rings [37] is impossible; they have to be replaced including the O-rings [38] underneath. To assemble new piston rings [37] carefully shape them like kidneys with locking ring pliers and insert the rings into the grooves; completely press the rings into the grooves smoothly using some round tool.

PLASTIC SERIES PULSATION DAMPENER – exploded view

Standard version (without ATEX)

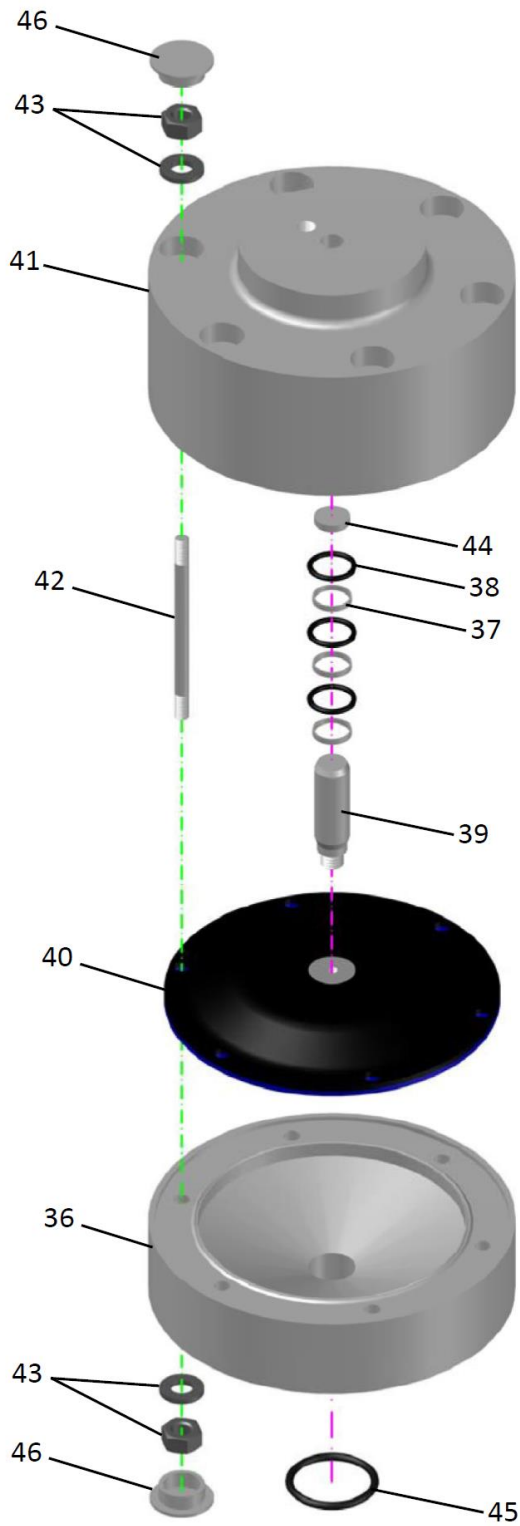

Conductive version (with ATEX)

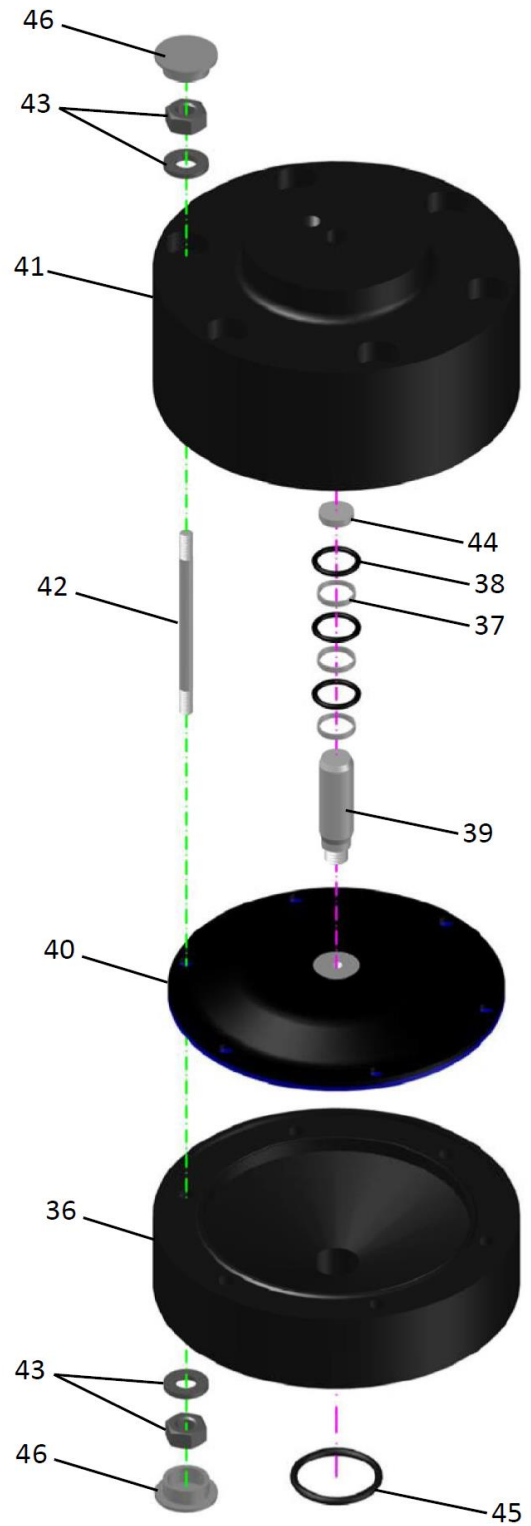

Spare parts list for Plastic Series Pulsation Dampeners, standard version (no ATEX)

			Pump size and material execution (P.P and T.P)								
Item	Part name	Quantity	Material	DM 08	DM 10	DM 15	DM 25	DM 40	DM 50	DM 80	
36.	Dampener housing	1	PE	8 08 001 20	8 10 001 20	8 15 001 20	8 25 001 20	8 40 001 20	8 50 001 20	8 80 001 20	
			PTFE	8 08 001 23	8 10 001 23	8 10 001 23	8 25 001 23	8 40 001 23	8 50 001 23	8 80 001 23	
37.	Piston ring	3	PPS-PTFE	1 08 90 18							
			PE				1 15 85 22	1 25 85 22	1 40 85 22	1 50 85 22	
38.	O-ring	3/6 ⁽¹⁾	NBR	1 08 82 10			1 15 85 10	1 25 85 10 ⁽¹⁾	1 40 85 10	1 50 85 10	
39.	Actuator shaft	1	PET	8 08 40 30			8 25 40 30				
			AISI 304					8 40 40 50	8 50 40 50	8 80 40 50	
40.	Diaphragm	1	EPDM		1 10 50 08		1 15 50 08	1 25 50 08	1 40 50 08	1 50 50 08	
			NBR		1 10 50 10		1 15 50 10	1 25 50 10	1 40 50 10	1 50 50 10	
			TFM(PTFE)	1 08 50 05	1 10 50 05		1 15 50 05	1 25 50 05	1 40 50 05	1 50 50 05	
			TFM(PTFE)-PFA	1 08 50 00	1 10 50 00		1 15 50 00	1 25 50 00	1 40 50 00	1 50 50 00	
41.	Dampener head	1	PE	8 08 203 20	8 10 203 20	8 25 203 20	8 40 203 20	8 50 203 20	8 80 203 20		
42.	Housing bolt	4/6**/8**	AISI 304	8 08 542 50	8 10 542 50	8 25 542 50**	8 40 542 50**	8 50 542 50***	8 80 542 50***		
43.	Nut with washer	8/12**/1	AISI 304	8 08 045 50	8 10 045 50	8 25 045 50**	8 40 045 50**	8 50 045 50***	8 80 045 50		
44.	Muffler	1	PE porous	8 08 99 35	8 10 99 35	8 25 99 35	8 40 99 35	8 50 99 35	8 80 99 35		
45.	Dampener housing O-ring ⁽¹⁾	1	EPDM	8 08 79 08	2 15 70 08	3 25 70 08	8 40 79 08	2 40 78 08	8 80 79 08		
			NBR		2 15 70 10	3 25 70 10	8 40 79 10	2 40 78 10	8 80 79 10		
			FEP/FKM core	8 08 79 04	2 15 70 04	3 25 70 04	8 40 79 04	2 40 78 04	8 80 79 04		
			FEP/Silicone core		2 15 70 03	3 25 70 03					
46.	Housing bolt	8/12**/1	PE	8 08 058 20	8 10 058 20	8 25 058 20**	8 40 058 20**	8 50 058 20***	8 80 058 20***		

⁽¹⁾ - standard material execution: EPDM for EPDM diaphragms, NBR for NBR diaphragms, FEP-FKM (FEP-Silicone where available) for TFM(PTFE) and TFM(PTFE)-PFA diaphragms

Spare parts list for Plastic Series Pulsation Dampeners, ex-proof version (with ATEX)

			Pump size and material execution (R.R and Z.R)							
Item	Part name	Quantity	Material	DM 08	DM 10	DM 15	DM 25	DM 40	DM 50	DM 80
36.	Dampener housing	1	PE conductive	8 08 001 21	8 10 001 21	8 15 001 21	8 25 001 21	8 40 001 21	8 50 001 21	8 80 001 21
			PTFE conductive	8 08 001 24	8 10 001 24	8 10 001 24	8 25 001 24	8 40 001 24	8 50 001 24	8 80 001 24
37.	Piston ring	3	PPS-PTFE	1 08 90 18						
			PE				1 15 85 22	1 25 85 22	1 40 85 22	1 50 85 22
38.	O-ring	3/6 ⁽¹⁾	NBR	1 08 82 10			1 15 85 10	1 25 85 10 ⁽¹⁾	1 40 85 10	1 50 85 10
39.	Actuator shaft	1	PET	8 08 40 30			8 25 40 30			
			AISI 304					8 40 40 50	8 50 40 50	8 80 40 50
40.	Diaphragm	1	EPDM		1 10 50 08		1 15 50 08	1 25 50 08	1 40 50 08	1 50 50 08
			NBR		1 10 50 10		1 15 50 10	1 25 50 10	1 40 50 10	1 50 50 10
			TFM(PTFE)	1 08 50 05	1 10 50 05		1 15 50 05	1 25 50 05	1 40 50 05	1 50 50 05
			TFM(PTFE)-PFA	1 08 50 00	1 10 50 00		1 15 50 00	1 25 50 00	1 40 50 00	1 50 50 00
41.	Dampener head	1	PE conductive	8 08 203 21	8 10 203 21	8 25 203 21	8 40 203 21	8 50 203 21	8 80 203 21	
42.	Housing bolt	4/6**/8***	AISI 304	8 08 542 50	8 10 542 50	8 25 542 50**	8 40 542 50**	8 50 542 50***	8 80 542 50***	
43.	Nut with washer	8/12**/16**	AISI 304	8 08 045 50	8 10 045 50	8 25 045 50**	8 40 045 50**	8 50 045 50***	8 80 045 50***	
44.	Muffler	1	PE porous	8 08 99 35	8 10 99 35	8 25 99 35	8 40 99 35	8 50 99 35	8 80 99 35	
45.	Dampener housing O-ring ⁽¹⁾	1	EPDM	8 08 79 08	2 15 70 08	3 25 70 08	8 40 79 08	2 40 78 08	8 80 79 08	
			NBR		2 15 70 10	3 25 70 10	8 40 79 10	2 40 78 10	8 80 79 10	
			FEP/FKM core	8 08 79 04	2 15 70 04	3 25 70 04	8 40 79 04	2 40 78 04	8 80 79 04	
			FEP/Silicone core		2 15 70 03	3 25 70 03				
46.	Housing bolt	8/12**/16**	PE	8 08 058 20	8 10 058 20	8 25 058 20**	8 40 058 20**	8 50 058 20***	8 80 058 20***	

⁽¹⁾ - standard material execution: EPDM for EPDM diaphragms, NBR for NBR diaphragms, FEP-FKM (FEP-Silicone where available) for TFM(PTFE) and TFM(PTFE)-PFA diaphragms

List of parts for spare part kits SET in Plastic Series Pulsation Dampener (both standard and ATEX versions)

Spare part kit set content	Item	Quantity	Pulsation Dampener Model	Size and material execution ^(A)																								
				DM 08		DM 10		DM 15		DM 25		DM 40		DM 50		DM 80												
				PTP, TTP, RTR, ZTR	PPP, TFP, RFR, ZFR	PEP, TEP, RER, ZER	PNP, TNP, RNR, ZNR	PTP, TTP, RTR, ZTR	PPP, TFP, RFR, ZFR	PEP, TEP, RER, ZER	PNP, TNP, RNR, ZNR	PTP, TTP, RTR, ZTR	PPP, TFP, RFR, ZFR	PEP, TEP, RER, ZER	PNP, TNP, RNR, ZNR	PTP, TTP, RTR, ZTR	PPP, TFP, RFR, ZFR	PEP, TEP, RER, ZER	PNP, TNP, RNR, ZNR									
Description	Part no.																											
	37.	3	Piston ring	1 08 90 18				1 15 85 22				1 25 85 22		1 40 85 22		1 80 85 22												
	38.	3/6 ⁽¹⁾	O-ring	1 08 82 10				1 15 85 10				1 25 85 10 ⁽¹⁾		1 40 85 10		1 80 85 10												
	39.	1	Actuator shaft	8 08 40 30				8 25 40 30				8 40 40 50		8 50 40 50		8 80 40 50												
	40.	1	Diaphragm	1 08 50 05	1 08 50 00	1 10 50 08	1 10 50 10	1 10 50 05	1 10 50 00	1 10 50 08	1 10 50 10	1 10 50 05	1 10 50 00	1 15 50 08	1 15 50 10	1 15 50 05	1 15 50 00	1 25 50 08	1 25 50 10	1 25 50 05	1 25 50 00	1 40 50 08	1 40 50 10	1 40 50 05	1 40 50 00	1 50 50 08	1 50 50 10	1 50 50 05
	44.	1	Muffler	8 08 99 35		8 10 99 35		8 15 99 35		8 25 99 35		8 40 99 35		8 50 99 35		8 80 99 35												

^(A) - typical pump material executions (other material executions may require different spare parts)

15.2. Appearance and dimensions (Pulsation Dampener only)

Standard version (without ATEX)

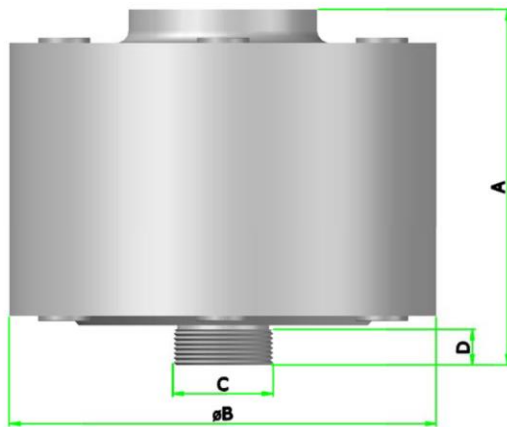

Conductive version (with ATEX)

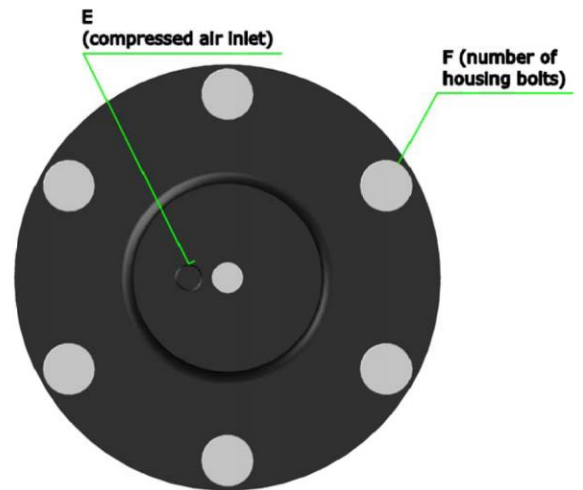
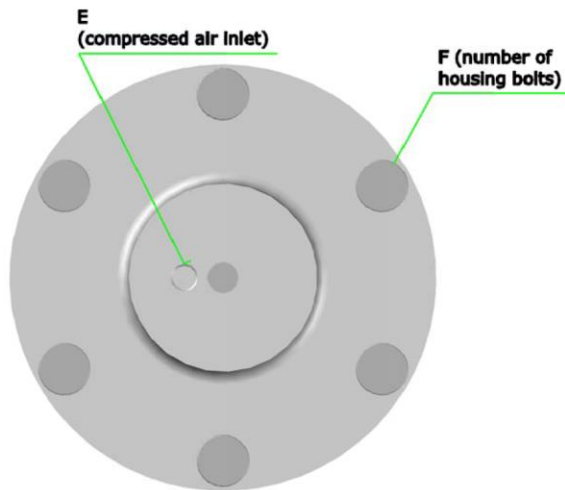
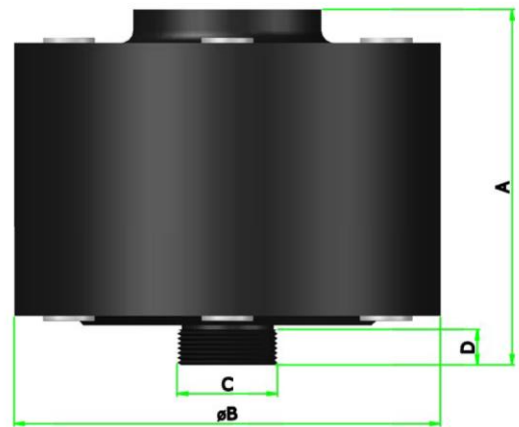

AODD Plastic Series Pulsation Dampeners – main dimensions (±2 mm)

Model/ Dimensions	DM 08 PTP, TTP DM 08 RTR, ZTR	DM 10 P.P, T.P DM 10 R.R, Z.R	DM 15 P.P, T.P DM 15 R.R, Z.R	DM 25 P.P, T.P DM 25 R.R, Z.R	DM 40 P.P, T.P DM 40 R.R, Z.R	DM 50 P.P, T.P DM 50 R.R, Z.R	DM 80 P.P, T.P DM 80 R.R, Z.R
A	84	93	98	138	170	216	287
øB	78	110	110	156	204	273	365
C	BSPP 3/8"	BSPP 1/2"	BSPP 1/2"	BSPP 1"	BSPP 1 1/2"	BSPP 2"	BSPP 3"
D	11	8	13	18	17	30	36
E	R 1/8"	R 1/8"	R 1/8"	R 1/8"	R 1/4"	R 1/4"	R 1/2"
F	4	4	4	6	6	8	8

Head material: PE (DM xx ..P), for ATEX – PE conductive (DM xx ..R)

Housing material (in contact with medium): PE (DM xx P.P), PTFE (DM xx I.P), for ATEX: PE conductive (DM xx R.R), PTFE conductive (DM xx Z.R)

Diaphragm material: EPDM (DM xx .E.), NBR (DM xx .N.), TFM/PTFE (DM xx .I.)

ATEX compliance: EEx II 2GD IIB Tx ("Tx" = T1+T5)

15.3. Appearance and dimensions (Plastic Pump with Pulsation Dampener assembled)

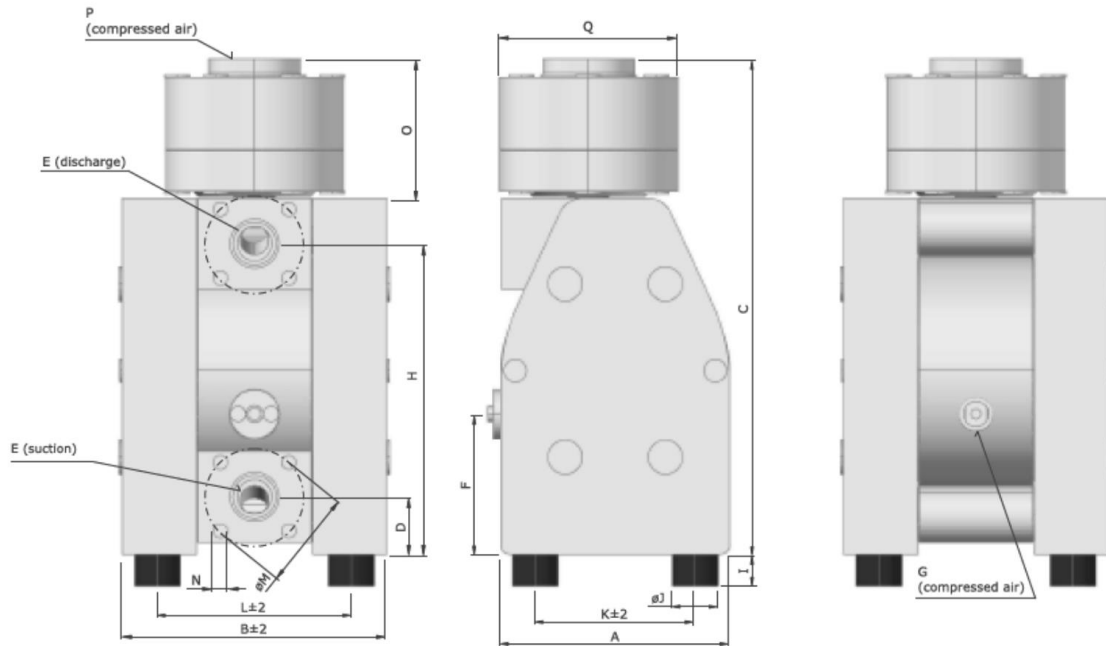

CAUTION: Dimensions of the ATEX Plastic Series Pumps with integrated Pulsation Dampener as for standard execution (above).

	A	B	C	D	E	F	G	H	I	ØJ	K	L	M	N	O	P	Q
DM 08/10	70	111	195	15	G 1/4"	58	R 1/8"	107	10	15	50	86	-	-	75	R 1/8"	76
DM 10/25	105	128	249	18	G 3/8"	84	R 1/8"	150	10	15	75	93	-	-	85	R 1/8"	110
DM 15/55	153	177	320	40	G 1/2"	87	R 1/4"	202	18	30	112	136	65	M12	85	R 1/8"	110
DM 25/125	200	232	432	50	G 1"	123	R 1/4"	272	28	40	140	170	85	M12	120	R 1/8"	156
DM 40/315	270	312	579	57	G 1 1/2"	109	R 1/2"	373	30	60	190	227	110	M16	153	R 1/4"	204
DM 50/565	350	385	726	52	G 2"	158	R 1/2"	478	30	60	270	282	125	M16	186	R 1/4"	273
DM 80/850	480	580	1061	100	DN80 DIN/PN16 (incl. G 3")	388	R 3/4"	690	40	75	395	495	160	M16	261	R 1/2"	360

15.4. Discharge port for PD (Pulsation Dampener)

Special discharge (outlet) port allows you to mount the PD directly on the pump already bought (this doesn't apply the pump ordered together with PD unit assembled in standard). In order to assemble the PD unit on the pump, standard outlet port has to be replaced with the special discharge port, as described below.

For the pumps from DM 08/10 up to DM 50/565 Plastic Series

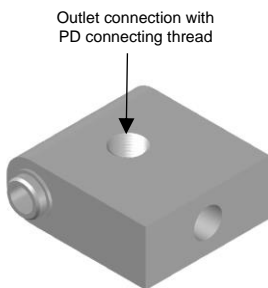

For the pumps from DM 15/55 up to DM 50/565 Plastic Series (equipped with F1, F2, F3 flange connection option) and for DM 80/850 Plastic Series (DIN PN16 flange connection and BSPP 3" thread in standard version)

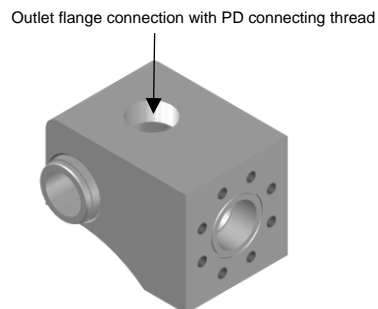

Quantity	Pump size		DM 08	DM 10	DM 15	DM 25	DM 40	DM 50	DM 80
	Description	Material	Part no.	Part no.	Part no.	Part no.	Part no.	Part no.	Part no.
1	Standard outlet connection for Pulsation Dampener	PE	2 08 27 20	2 10 27 20	2 15 27 20	2 25 27 20	2 40 27 20	2 50 27 20	
		PTFE	2 08 27 23	2 10 27 23	2 15 27 23	2 25 27 23	2 40 27 23	2 50 27 23	
		PE conductive	2 08 27 21	2 10 27 21	2 15 27 21	2 25 27 21	2 40 27 21	2 50 27 21	
		PTFE conductive	2 08 27 24	2 10 27 24	2 15 27 24	2 25 27 24	2 40 27 24	2 50 27 24	
1	Flange outlet connection for Pulsation Dampener (with F1, F2, F3 flange for DM 15/55 up to DM 50/565 and PN16 flange for DM 80/850 Pump only)	PE			2 15 26 20	2 25 26 20	2 40 26 20	2 50 26 20	2 80 27 20
		PTFE			2 15 26 23	2 25 26 23	2 40 26 23	2 50 26 23	2 80 27 23
		PE conductive			2 15 26 21	2 25 26 21	2 40 26 21	2 50 26 21	2 80 27 21
		PTFE conductive			2 15 26 24	2 25 26 24	2 40 26 24	2 50 26 24	2 80 27 24

16. Optional Equipment

**Additional information to the operating and installation instructions
ought to be studied before installing the pump**

For special requirements DELLMECO pneumatic diaphragm pumps of the Plastic Series can be furnished with several optional equipment. The pump code informs, which of these are included in the pump.

16.1. Barrier Chamber System (Option codes: BC1, BC2, BC3)

To comply with high safety standards, the barrier system replaces the standard diaphragm [4] by a tandem arrangement of two EPDM diaphragms [4, 59] and two barrier chambers [53, 54] of conductive PE filled with a non-conductive liquid (de-ionized water) in between. To ensure the correct operation of the pump, the barrier chambers [53, 54] have to be filled completely. Therefore, they are monitored by liquid sensors [60]. After loosening the plug [57] each barrier liquid can be refilled. In case a diaphragm in contact with pumped liquid breaks, the conductivity of the barrier liquid rises which is registered by the conductivity sensors [56]. The minimum conductivity of 22 μ S covers a wide range of media. After using for some time the de-ionized water can be polluted with germs. In this case the water needs to be replaced.

The barrier system is available in three variations:

- BC 1 Barrier system with sensors, standard
- BC 2 Barrier system complete with sensors and controllers
- BC 3 Barrier system complete with sensors and controllers for explosion-proof zone

The four conductivity sensors [56] are pre-installed. After connection of the wire (wire not part of supply) only the PG-threads have to be screwed onto. Both liquid sensors [60] are installed completely.

The sensors can either be connected to an existing controller (code BC1) or to the controller included (code BC2 / BC3). The wiring diagram and technical data can be found on the controller itself. For further details, please refer to the data delivered by the manufacturers of the components.

The controllers have to be installed in a suitable cabinet outside ATEX area.

CAUTION: *When assembling BC3 Option in the explosion-proof zone, controllers must be installed in a suitable cabinet outside ATEX area. DELLMECO **DO NOT** offer ATEX-approved cabinets for installing controllers.*

Exploded view, Barrier Chamber system for DM 10/25, Plastic Series

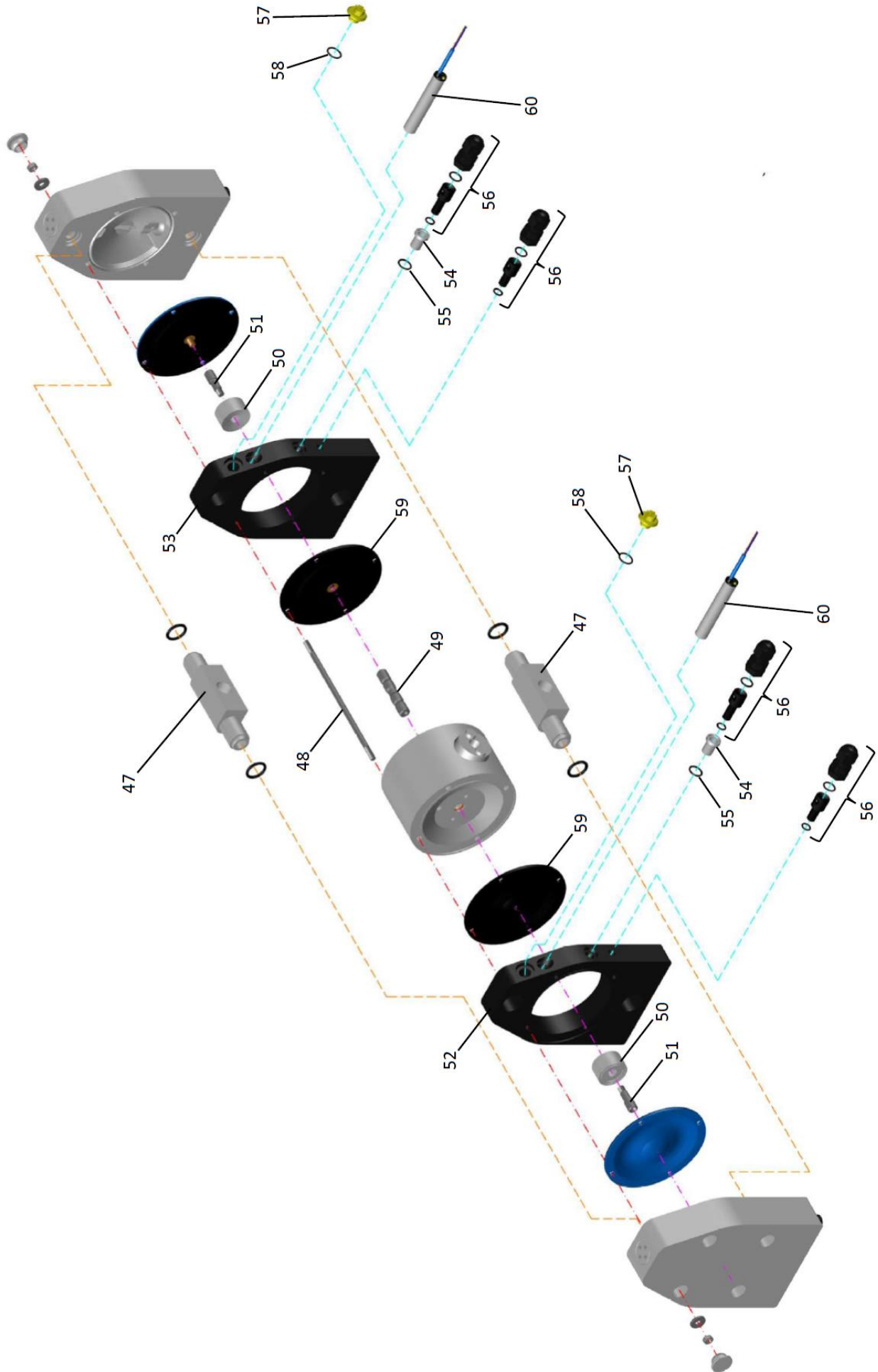

Exploded view, Barrier Chamber system, pumps from DM 15/55 to 50/565, Plastic Series

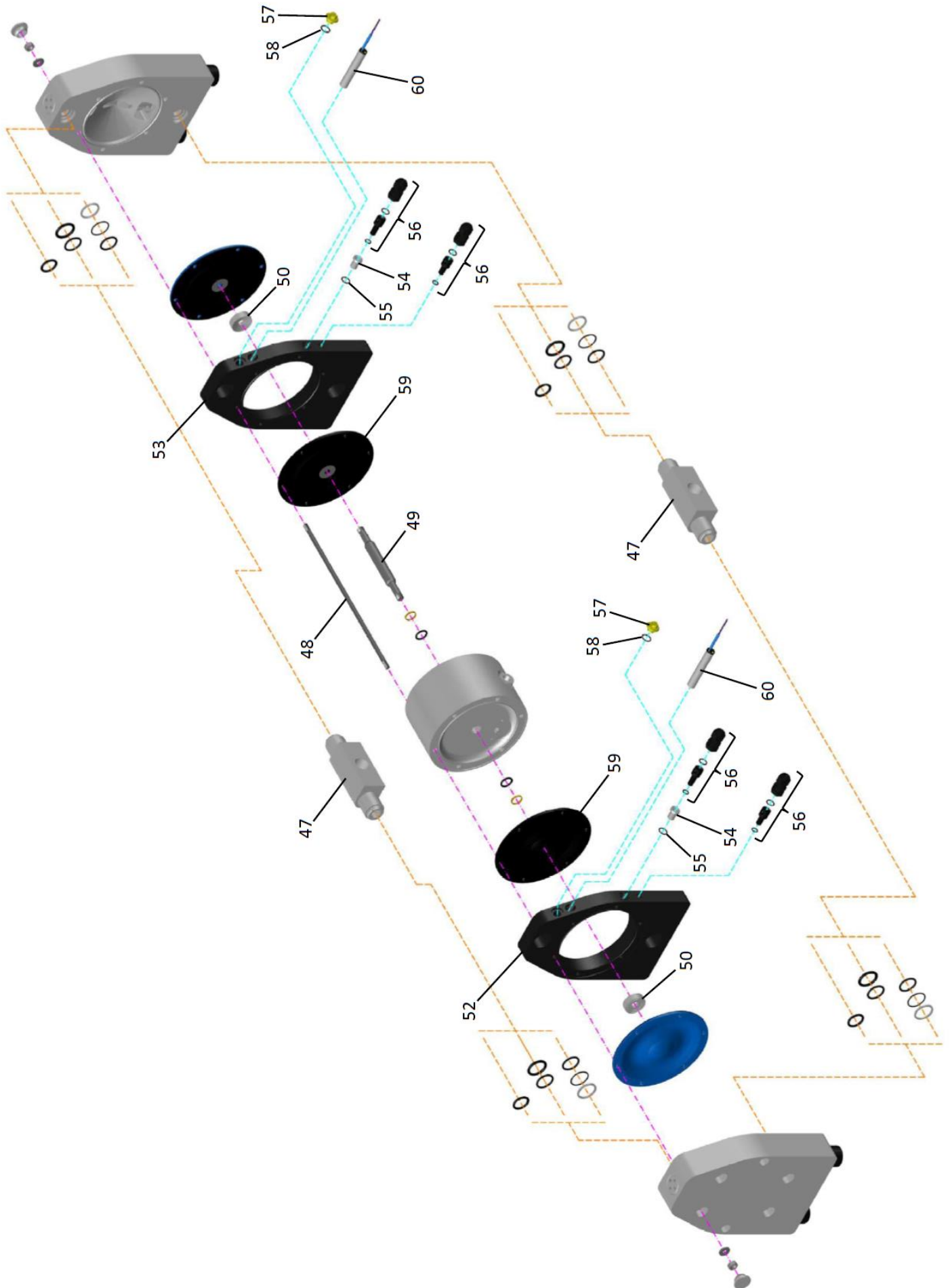

Exploded view, Barrier Chamber system for DM 80/850, Plastic Series

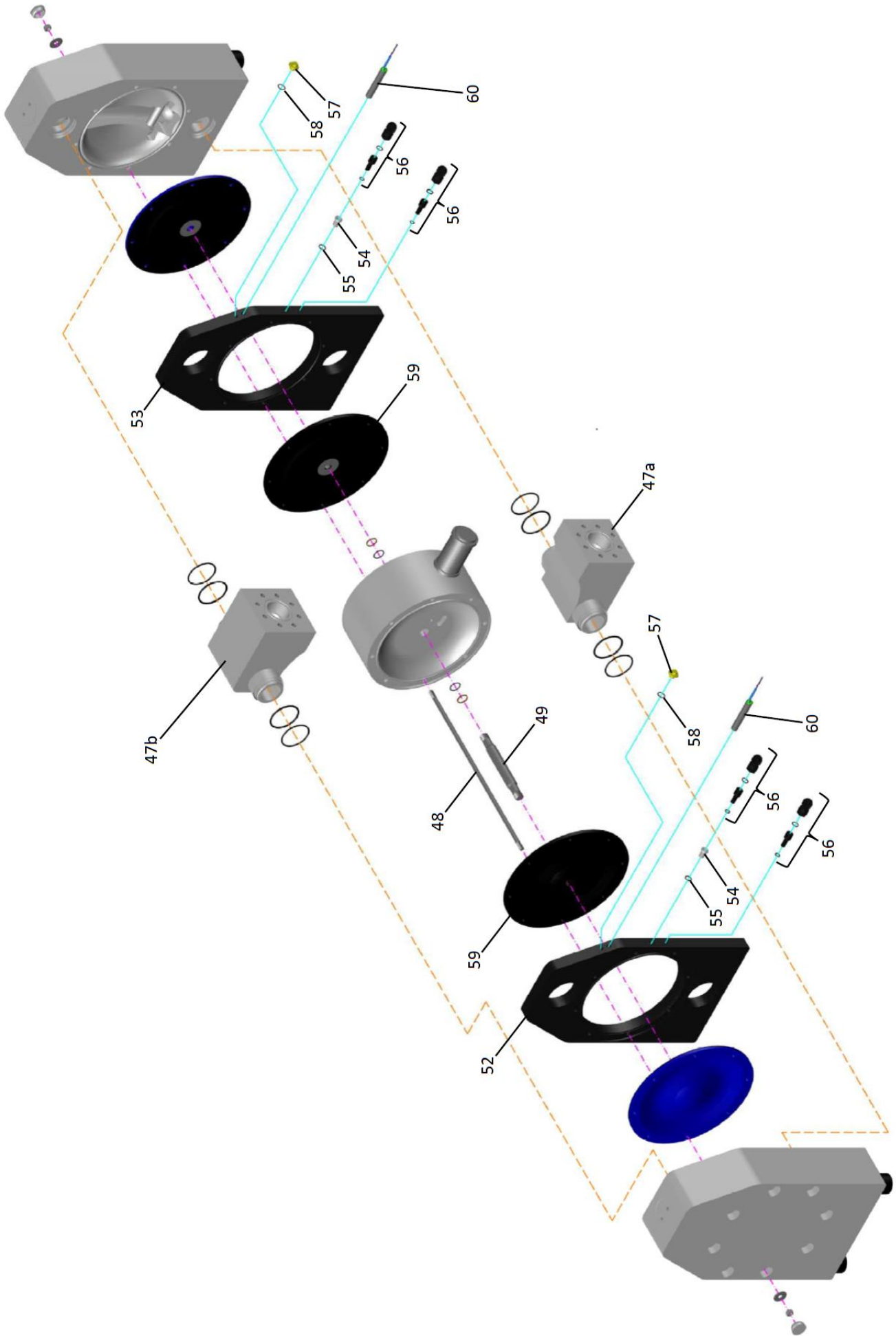

Spare part list, barrier chamber system

Pump size:				DM 10	DM 15	DM 25	DM 40	DM 50	DM 80	
Code	Item	Quantity	Part name	Material	Part no.	Part no.	Part no.	Part no.	Part no.	
BC 1	47.	2	Suction / Discharge Ports	PE	2 10 32 20	2 15 32 20	2 25 32 20	2 40 32 20	2 50 32 20	
				PTFE	2 10 32 23	2 15 32 23	2 25 32 23	2 40 32 23	2 50 32 23	
				PE conductive	2 10 32 21	2 15 32 21	2 25 32 21	2 40 32 21	2 50 32 21	
				PTFE conductive	2 10 32 24	2 15 32 24	2 25 32 24	2 40 32 24	2 50 32 24	
	47a.	1	Suction port	PE						2 80 132 20
				PTFE						2 80 132 23
				PE conductive						2 80 132 21
				PTFE conductive						2 80 132 24
	47b.	1	Discharge port	PE						2 80 232 20
				PTFE						2 80 232 23
				PE conductive						2 80 232 21
				PTFE conductive						2 80 232 24
	48.	4 / 6* / 8**	Barrier chamber housing bolt	AISI 304	9 10 42 50	9 15 42 50*	9 25 42 50*	9 40 42 50**	9 50 42 50**	9 80 42 50**
	49.	1	Barrier chamber set screw shaft	AISI 304	1 10 41 50	1 15 41 50	1 25 41 50	1 40 41 50	1 50 41 50	1 80 41 50
	50.	2	Spacer	PET	1 10 63 30	1 15 63 30	1 25 63 30			
	51.	2	Spacer bolt	AISI 304	1 10 43 50					
	52.	1	Left barrier chamber	PE conductive	2 10 02 21	2 15 02 21	2 25 02 21	2 40 02 21	2 50 02 21	2 80 02 21
	53.	1	Right barrier chamber	PE conductive	2 10 102 21	2 15 102 21	2 25 102 21	2 40 102 21	2 50 102 21	2 80 102 21
	54.	2	Sensor sleeve	PE	2 10 62 20	2 15 62 20	2 25 62 20	2 40 62 20	2 50 62 20	2 80 62 20
	55.	2	Sensor sleeve O-ring	FKM	1 08 82 09	1 08 82 09	1 08 82 09	1 08 82 09	1 08 82 09	1 80 82 09
56.	4	Conductivity sensor	diverse	9 15 15 00	9 15 15 00	9 15 15 00	9 15 15 00	9 15 15 00	9 80 15 00	
57.	2	Plug	PA	1 15 48 40	1 15 48 40	1 15 48 40	1 15 48 40	1 15 48 40	1 80 48 40	
58.	2	Plug O-ring	FKM	1 15 74 09	1 15 74 09	1 15 74 09	1 15 74 09	1 15 74 09	1 80 74 09	
59.	2	Inner diaphragm	EPDM	1 10 51 08	1 15 51 08	1 25 51 08	1 40 51 08	1 50 51 08	1 80 51 08	
60.	2	NAMUR liquid sensor	diverse	9 15 12 00	9 15 12 00	9 15 12 00	9 15 12 00	9 15 12 00	9 15 12 00	
BC 2	as BC1, but additionally contains:									
	-	1	Controller	diverse	9 15 14 00	9 15 14 00	9 15 14 00	9 15 14 00	9 15 14 00	9 15 14 00
	-	1	Conductivity measuring transmitter	diverse	9 15 13 00	9 15 13 00	9 15 13 00	9 15 13 00	9 15 13 00	9 15 13 00
BC 3	as BC2, but for EEx II IIB:									
	-	1	Controller	diverse	9 15 14 00	9 15 14 00	9 15 14 00	9 15 14 00	9 15 14 00	9 15 14 00
	-	1	Conductivity measuring transmitter	diverse	9 15 08 00	9 15 08 00	9 15 08 00	9 15 08 00	9 15 08 00	9 15 08 00

Appearance and dimensions (Plastic Series standard and ATEX Pump with Barrier Chamber System)

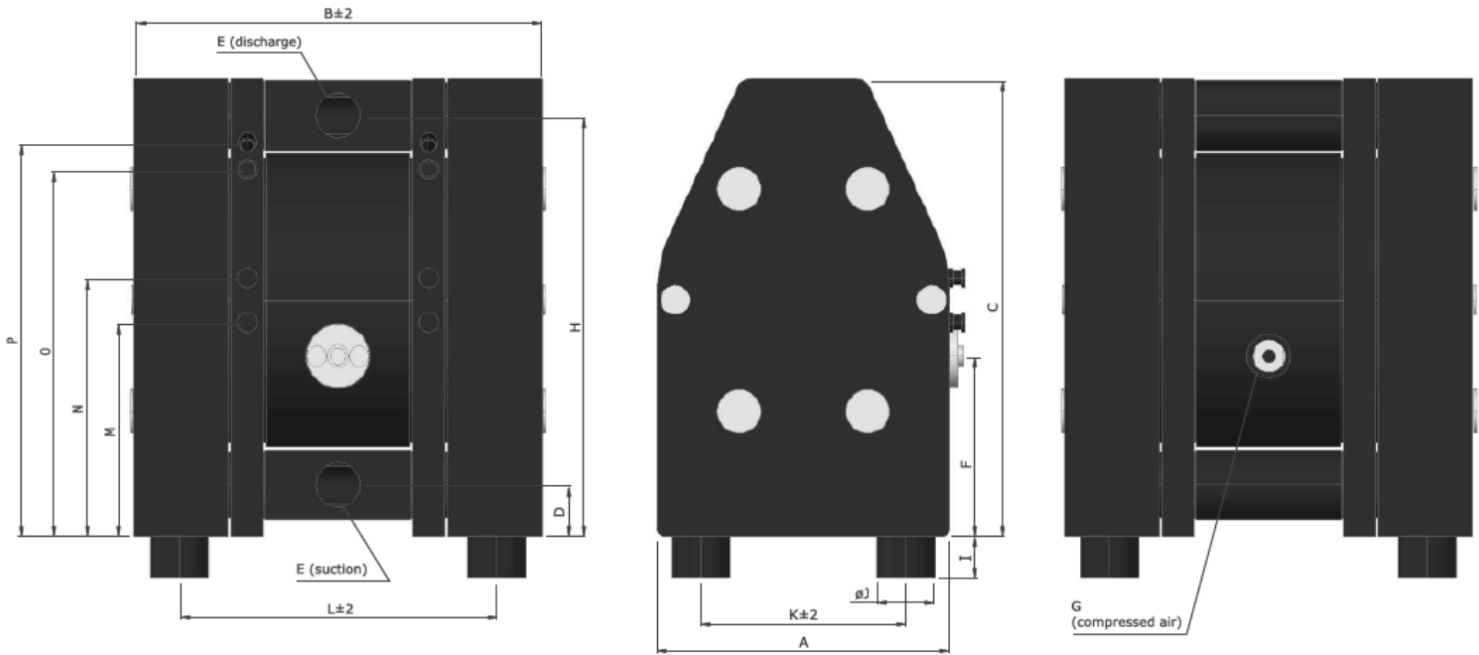

	A	B	C	D	E	F	G	H	I	ØJ	K	L	M	N	O	P
DM 10/25	105	173	164	18	BSPP 3/8"	84	R 1/8"	150	10	15	75	138	61	84	128	146
DM 15/55	153	223	235	25	BSPP 1/2"	87	R 1/4"	217	18	30	112	182	86	111	191	209
DM 25/125	200	282	312	35	BSPP 1"	123	R 1/4"	287	28	40	140	220	146	176	250	270
DM 40/315	270	360	426	42	BSPP 1 1/2"	109	R 1/2"	388	30	60	190	276	204	229	349	369
DM 50/565	350	433	540	45	BSPP 2"	158	R 1/2"	485	30	60	270	335	253	278	443	463
DM 80/850	480	680	800	100	DIN PN16/ BSPP 3"	388	R 3/4"	690	40	75	395	585	358	418	595	623

16.2. Stroke Counting (Option codes: SC1, SC2, SC3, SC5, SC6)

a) Code SC1, SC2, SC3

An inductive sensor is installed in the central pump housing to count the strokes. The diaphragm's shaft movement is scanned without contact by this sensor – a safe form of monitoring totally independent of external influences and the pump's mode of operation. The issued sensor pulses can be output to existing detectors or to a stroke counter, which can also be supplied on request. When the preset value is reached, the stroke counter outputs a signal which can then be processed further, for instance in order to shut down the pump via a solenoid valve.

This is available for the pumps starting from DM 15/55 up to DM 80/850 of the Plastic Series. In smaller Plastic Series Pumps (DM 08/10 and DM 10/25 sizes), only pneumatic stroke counting option (SC5 or SC6) is available.

The inductive stroke counting system is available in three variations:

- SC 1 Stroke sensor (NAMUR), also for explosion-proof zone
- SC 2 Stroke counting system complete with sensor and stroke counter
- SC 3 Stroke counting system complete with sensor, stroke counter and controller for explosion-proof zone

In case only the sensor is included (code SC1), it has to be connected to an existing controller with NAMUR inlet. For applications an explosion-proof device is required for (code SC3) the intrinsically safe controller has to be installed between the sensor and the counter. The wiring diagram and technical data can be found on the electric units themselves. For further details, please refer to the data delivered by the manufacturers of the components. The controllers have to be installed in a suitable cabinet.

CAUTION: When assembling SC3 Option in the explosion-proof zone, stroke counter and controller must be installed in a suitable cabinet (ATEX approved).

Exploded view, Stroke Counting SC1, SC2, SC3 system, pumps from DM 15/55 to DM 80/850, Plastic Series

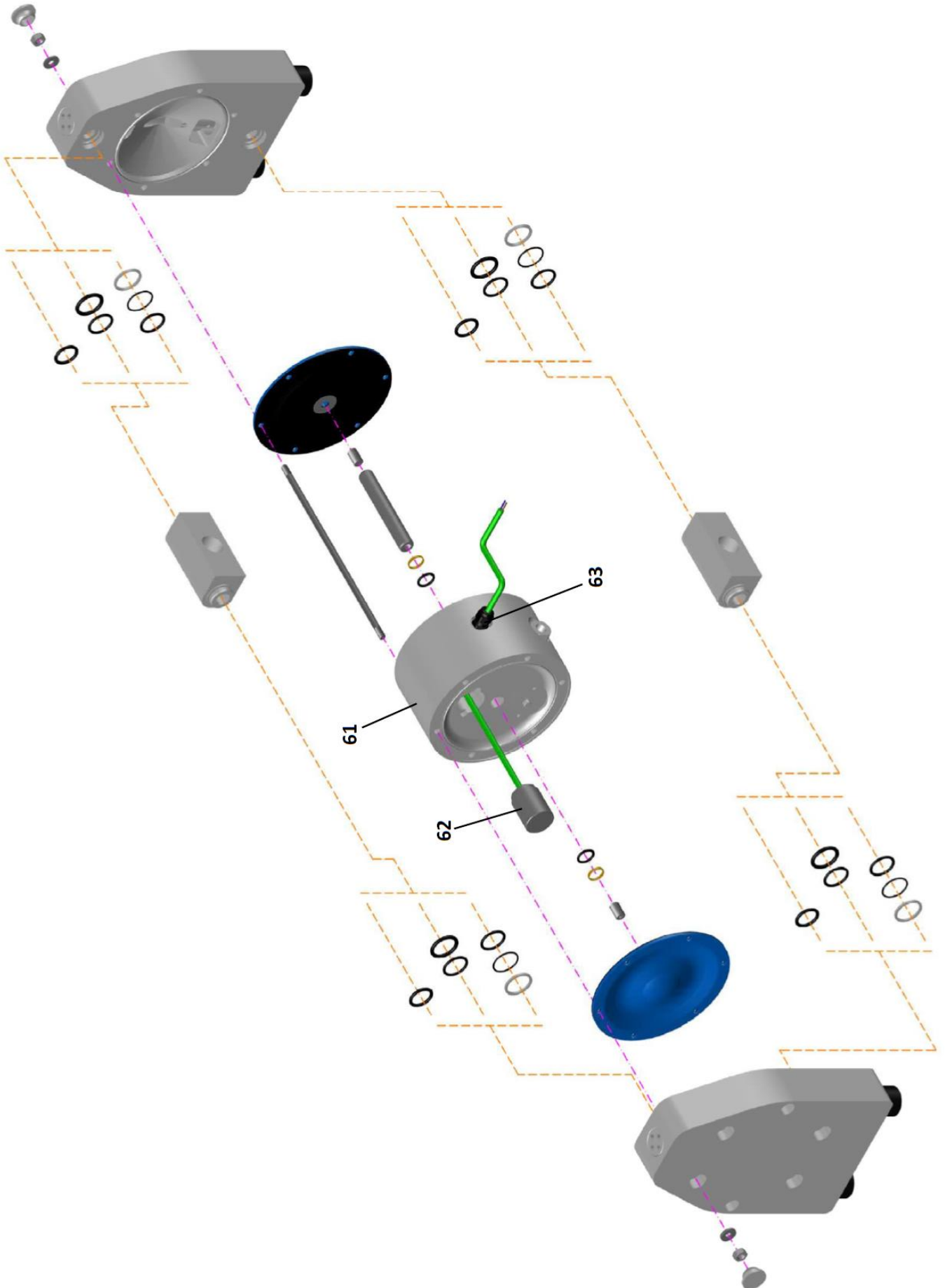

Spare part list, Stroke Counting Options: SC1, SC2, SC3 (inductive sensor)

Plastic Pump size:				DM 15/55	DM 25/125	DM 40/315	DM 50/565	DM 80/850
Code	Item	Quantity	Part name	Material	Part no.	Part no.	Part no.	Part no.
SC 1	61.	1	Center housing for sensor	PE	1 15 09 20	1 25 09 20	1 40 09 20	1 50 09 20
				PE conductive	1 15 09 21	1 25 09 21	1 40 09 21	1 50 09 21
	62.	1	Stroke sensor	Diverse	9 15 16 00			
	63.	1	Cable gland	Diverse	9 15 367 00			
SC 2	as SC 1, but additionally contains:							
	-	1	Clamp amplifier	Diverse	9 15 18 00			
	-	1	Stroke counter	Diverse	9 15 17 00			
SC 3	as SC 1, but additionally contains:							
	-	1	Level controller	Diverse	9 15 14 00			
	-	1	Stroke counter	Diverse	9 15 17 00			

b) Code SC5, SC6

Differently from the optional equipment codes SC1-SC3, the strokes of the pump are registered pneumatically on the codes SC5 and SC6. The pressure transmitter registers the changes in pressure within the air chamber behind one of the diaphragms and it converts the pneumatic impulse into an electrical signal.

This option is available for all the pumps of the Plastic Series – from DM 08/10 up to DM 80/850 size. It is not applicable for ATEX Plastic Series Pumps (ATEX Certificate for SC5 and SC6 is not available).

The pneumatic stroke counting system is available in two types:

- **SC 5** consist of:
 - pressure transmitter 1-10 bar
 - quick coupling for pressure transmitter-hose connection
 - socket with cable (for pressure transmitter)
 - adaptor elbow NPT 1/8"
 - hose DN 4/6; 2,5m
- **SC 6** consist of:
 - SC 5 plus stroke counter

For assembly, screw the quick-coupling connector into the pressure transmitter and the adaptor elbow into the additional air connection of the pump, located on the central housing (it is possible that the adaptors are already installed). The position of the additional air inlet varies depending in the pump type and the pump size. Link up both adaptor and quick-coupling with the hose. Connect the socket to the electrical connection plug of the pressure transmitter and the socket cable to existing registering devices (Option SC5) resp. to the enclosed stroke counter (Option SC6). Technical data, connection schemes and further details can be found in the technical documentation delivered by the manufacturers of the pressure transmitter and the stroke counter.



! The pneumatic stroke counting system requires a minimum air pressure of 1.5 bar for optimal function.

The air inlet for the pneumatic stroke counting system must not be confused with the actual air inlet of the pump. Therefore, you will find some advises adapted to the pump type and the pump size.

Exploded view, Stroke Counting SC5, SC6 Option, Plastic Series

DM 08/10 and DM 10/25 Pumps with SC5 Option

DM 15/55, ..., DM 80/850 Pumps with SC5 Option

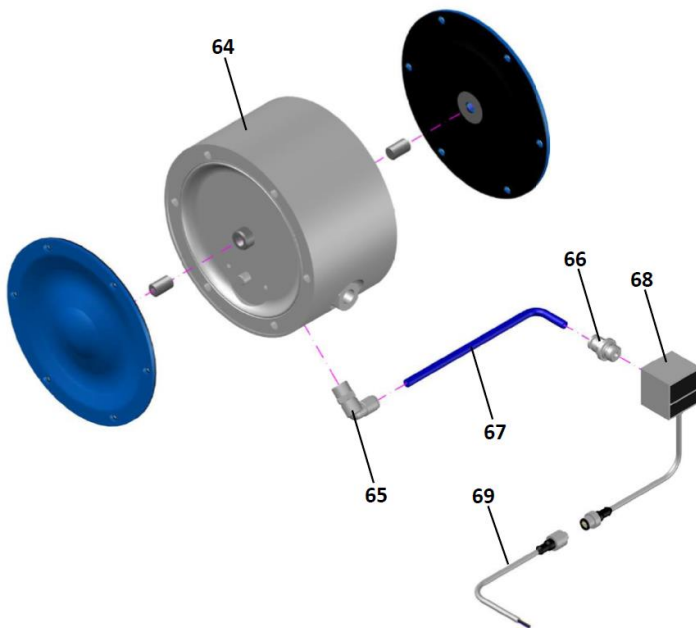
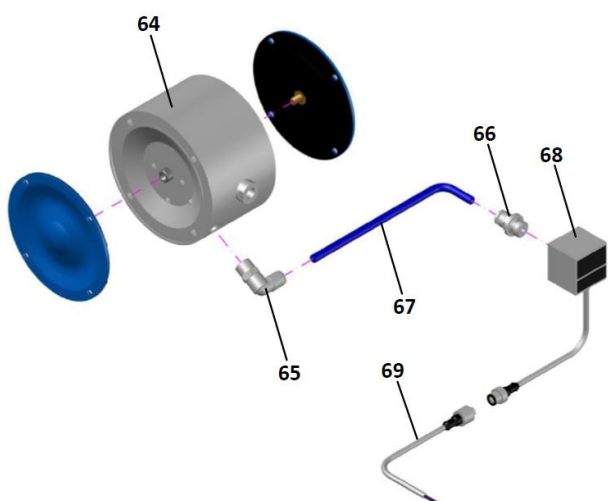

Spare part list, Stroke Counting Options: SC5, SC6 (pneumatic electronic sensor)

					Pump size:							
					DM 08/10	DM 10/25	DM 15/55	DM 25/125	DM 40/315	DM 50/565	DM 80/850	
Code	Item	Quantity	Part name	Material	Part no.	Part no.	Part no.	Part no.	Part no.	Part no.	Part no.	
SC 5	64.	1	Center housing with additional air connection 1/8"	PE	1 08 109 20	1 10 109 20	1 15 109 20	1 25 109 20	1 40 109 20	1 50 109 20	1 80 109 20	
				PE conductive	1 08 109 21	1 10 109 21	1 15 109 21	1 25 109 21	1 40 109 21	1 50 109 21	1 80 109 21	
	65.	1	Adaptor elbow	Diverse	1 08 092 28							
	66.	1	Adaptor straight	Diverse	1 08 192 28							
	67.	1	Hose 2,5 m	PUR	1 08 292 20							
	68.	1	Pressure transmitter	Diverse	9 08 28 00							
	69.	1	Socket with cable 2,5m	Diverse	1 08 392 00							
SC 6	as SC5, but additionally contains:											
	-	1	Stroke counter	Diverse	9 15 17 00							

16.3. Diaphragm Monitoring (Option codes: DM1, DM2)

Although DELLMECO diaphragms with integrated metal core are designed for an optimum service life, the diaphragm remains a wear part. If it breaks, liquid can leak into the center housing and possibly emerge through the muffler. This can be prevented simply and effectively with the DELLMECO diaphragm monitoring.

A capacitive diaphragm sensor [70] is mounted in the specially prepared exhaust muffler [71]. This sensor registers any liquid approaching it, no matter whether the liquid is conductive or not. Hence, fast reaction to a damage of a diaphragm becomes possible (sensor in contact with liquid sends a signal to the controller). In case of humid surrounding area a false alert may occur despite operating the pump with dried compressed air.

The diaphragm monitoring system is available in two variations:

- DM1 Diaphragm sensor (NAMUR), also for explosion-proof area
- DM2 Diaphragm monitoring system complete with sensor and controller

The diaphragm sensor can either be connected to an existing controller with NAMUR inlet (Option DM1) or to the controller included (Option DM2). The wiring diagram and technical data can be found on the controller itself. For further details, please refer to the data delivered by the manufacturers of the components. The controllers have to be installed in a suitable cabinet.

Exploded view, Diaphragm Monitoring DM1, DM2 Option – pumps from DM 08/10 to DM 50/565, Plastic Series

DM1 Option before assembling on the muffler

DM1 Option ready to install

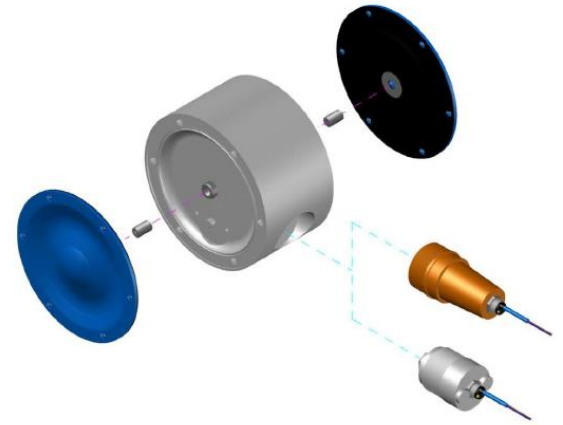
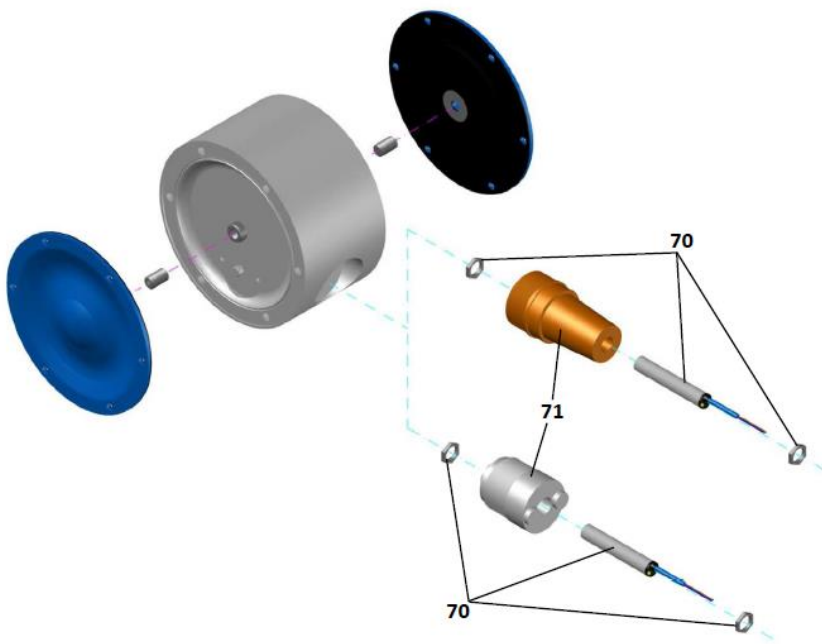

Exploded view, Diaphragm Monitoring DM Option – Pump 80/850 P(T).. Series

DM1 Option before assembling on the muffler

DM1 Option ready to install

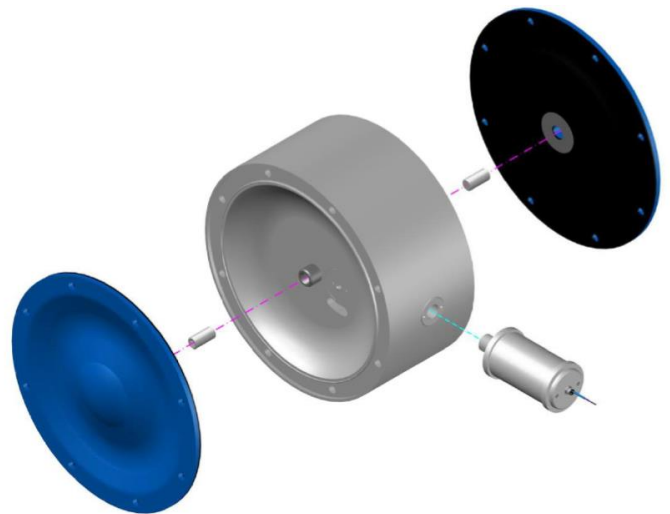
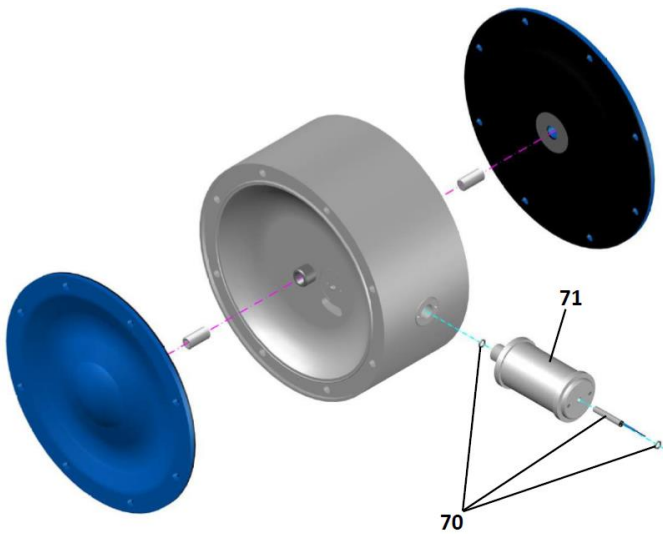

Spare part list, diaphragm monitoring (DM1, DM2)

Pump size					08/10	10/25	15/55	25/125	40/315	50/565	80/850
Code	Item	Q-ty	Part name	Material	Part no.						
DM1	70.	1	Diaphragm sensor, NAMUR	Diverse	9 15 19 00						
	71.	1	Exhaust muffler for DM Option (with new thread)	PE porous	1 08 399 35	1 15 399 35	1 40 399 35	1 50 399 35	1 80 99 00		
Bronze				1 08 399 86	1 15 399 86	1 40 399 86	1 50 399 86				
DM2	as DM1, but additionally contains:										
	-	1	Level controller	diverse	9 15 14 00						

16.4. Flange Connections (Option codes: F1, F2, F3, F1.1, F2.1, F3.1, F4, F7, F8, F9, F4-I, F7-I, F8-I, F9-I, F4.1, F7.1, F8.1, F9.1, F4.1-I, F7.1-I, F8.1-I, F9.1-I)

This version offers the possibility to use flange connectors according to: **DIN/PN10** (options: **F1, F1.1** with EPDM sealing, **F2, F2.1** with NBR sealing, **F3, F3.1** with FEP-FKM sealing), **JIS 10K** (option **F4, F4.1**), **PN10 DIN 2576** (option **F7, F7.1**), **ANSI 150 RF-SO** (option **F8, F8.1**), or **PN10/16 DIN 2277/2278** (option **F9, F9.1**).

For the options **F1, F2, F3** (PE, PE conductive material) and **F1.1, F2.1, F3.1** (PTFE, PTFE conductive material) – thread bushings, made of stainless steel to fix the flanges, are inserted into the inlet/outlet connection. In-/outlet connections are made from the same material as the wetted parts of the pump. Sealing O-rings (2 pcs per 1 pump – available only on demand) have to be inserted into the grooves of the manifolds to improve sealing before connecting the pump.

DM 80/850 Plastic Series Pumps (both non-ATEX and ATEX versions) are standardly equipped with integrated flange connections in acc. with PN16 DIN 2278, but it is also possible to use BSPP 3" female thread connection. Other type of 3" Pump flange connections (DN80) available only on request!

For the options: **F4, F7, F8, F9** (PE, PE conductive material) and **F4.1, F7.1, F8.1, F9.1** (PTFE, PTFE conductive material) – thread-mounted pipe is made from the same material as the wetted parts of the pump, but the movable flange collar is always made from PE conductive material, because it is not in direct contact with liquid (both parts are not integrated). Also available options: **F4-I, F7-I, F8-I, F9-I** (PE and PE conductive integrated flanges) and options: **F4.1-I, F7.1-I, F8.1-I, F9.1-I** (PTFE and PTFE conductive integrated flanges). More details on the below drawings:

F1, F2, F3 (PE, PE cond.),
F1.1, F2.1, F3.1 (PTFE, PTFE cond.)
flanges: inlet (bottom)/outlet (top)

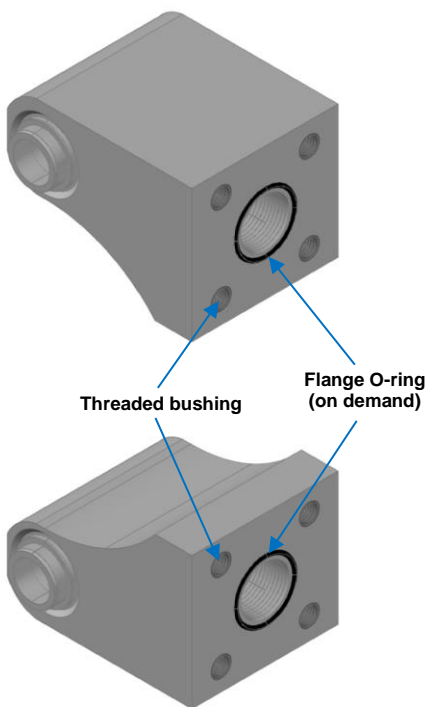

F4, F7, F8, F9 (PE, PE cond.),
F4.1, F7.1, F8.1, F9.1 (PTFE, PTFE cond.)
thread-mounted flanges: inlet (bottom)/outlet (top)

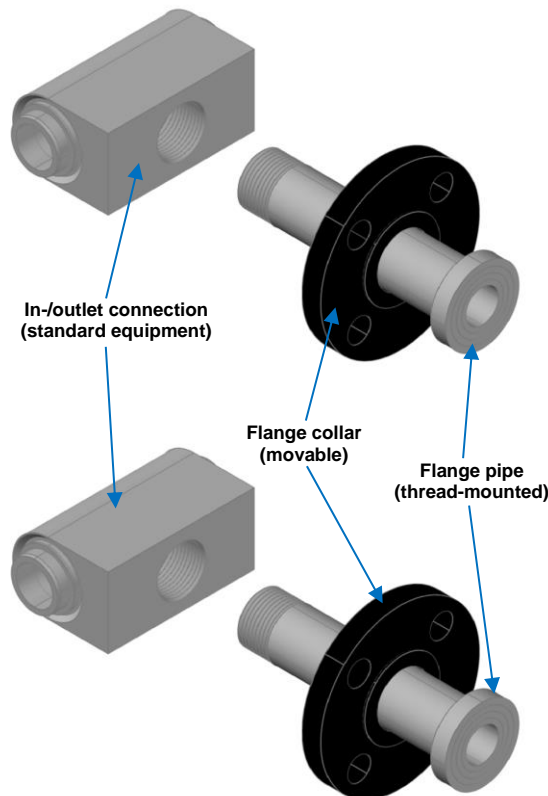

F4-I, F7-I, F8-I, F9-I (PE, PE cond.),
F4.1-I, F7.1-I, F8.1-I, F9.1-I (PTFE, PTFE cond.)
integrated flanges: inlet (bottom)/outlet (top)

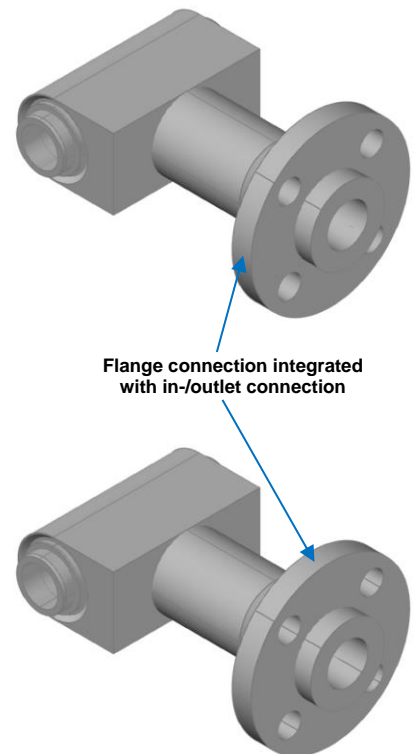

Spare part list, flange connection options

Pump size:					DM 15	DM 25	DM 40	DM 50
Code	Item	Quantity	Part name	Material	Part no.	Part no.	Part no.	Part no.
F1	-	2	DIN/PN10 flange connection (with inserted threaded bushings)	PE	2 15 25 20	2 25 25 20	2 40 25 20	2 50 25 20
	-	2		PE conductive	2 15 25 21	2 25 25 21	2 40 25 21	2 50 25 21
	-	2	Flange O-ring	EPDM	3 25 70 08	2 25 78 08	2 40 78 08	2 50 78 08
F2	as F1, but:							
	-	2	Flange O-ring	NBR	3 25 70 10	2 25 78 10	2 40 78 10	2 50 78 10
F3	as F1, but:							
	-	2	Flange O-ring	FEP/FKM core	3 25 70 04	2 25 78 04	2 40 78 04	2 50 78 04
	-	2		FEP/Silicone core		2 25 78 03	2 40 78 03	
F1.1	-	2	DIN/PN10 flange connection (with inserted threaded bushings)	PTFE	2 15 25 23	2 25 25 23	2 40 25 23	2 50 25 23
	-	2		PTFE conductive	2 15 25 24	2 25 25 24	2 40 25 24	2 50 25 24
	-	2	Flange O-ring	EPDM	3 25 70 08	2 25 78 08	2 40 78 08	2 50 78 08
F2.1	as F1.1, but:							
	-	2	Flange O-ring	NBR	3 25 70 10	2 25 78 10	2 40 78 10	2 50 78 10
F3.1	as F1.1, but:							
	-	2	Flange O-ring	FEP/FKM core	3 25 70 04	2 25 78 04	2 40 78 04	2 50 78 04
	-	2		FEP/Silicone core		2 25 78 03	2 40 78 03	
F4	-	2	Flange pipe	PE	2 15 125 20	2 25 125 20	2 40 125 20	2 50 125 20
	-	2		PE conductive	2 15 125 21	2 25 125 21	2 40 125 21	2 50 125 21
	-	2	JIS 10K flange collar	PE conductive	2 15 525 21	2 25 525 21	2 40 525 21	2 50 525 21
F7	as F4, but:							
	-	2	PN10/DIN 2576 flange collar	PE conductive	2 15 225 21	2 25 225 21	2 40 225 21	2 50 225 21
F8	as F4, but:							
	-	2	ANSI 150 RF-SO flange collar	PE conductive	2 15 325 21	2 25 325 21	2 40 325 21	2 50 325 21
F9	as F4, but:							
	-	2	PN16 DIN 2278 flange collar	PE conductive	2 15 425 21	2 25 425 21	2 40 425 21	2 50 425 21
F4.1	-	2	Flange pipe	PTFE	2 15 125 23	2 25 125 23	2 40 125 23	2 50 125 23
	-	2		PTFE conductive	2 15 125 24	2 25 125 24	2 40 125 24	2 50 125 24
	-	2	JIS 10K flange collar	PE conductive	2 15 525 21	2 25 525 21	2 40 525 21	2 50 525 21
F7.1	as F4.1, but:							
	-	2	PN10/DIN 2576 flange collar	PE conductive	2 15 225 21	2 25 225 21	2 40 225 21	2 50 225 21
F8.1	as F4.1, but:							
	-	2	ANSI 150 RF-SO flange collar	PE conductive	2 15 325 21	2 25 325 21	2 40 325 21	2 50 325 21
F9.1	as F4.1, but:							
	-	2	PN16 DIN 2277/2278 flange collar	PE conductive	2 15 425 21	2 25 425 21	2 40 425 21	2 50 425 21
F4-I	-	2	JIS 10K flange integrated with inlet/outlet connection	PE	2 15 826 20	2 25 826 20	2 40 826 20	2 50 826 20
	-	2		PE conductive	2 15 826 21	2 25 826 21	2 40 826 21	2 50 826 21
F7-I	-	2	PN10 DIN2576 flange integrated with inlet/outlet connection	PE	2 15 626 20	2 25 626 20	2 40 626 20	2 50 626 20
	-	2		PE conductive	2 15 626 21	2 25 626 21	2 40 626 21	2 50 626 21
F8-I	-	2	ANSI 150 RF flange integrated with inlet/outlet connection	PE	2 15 126 20	2 25 126 20	2 40 126 20	2 50 126 20
	-	2		PE conductive	2 15 626 21	2 25 126 21	2 40 126 21	2 50 126 21
F9-I	-	2	PN16 DIN 2278 flange integrated with inlet/outlet connection	PE	2 15 926 20	2 25 926 20	2 40 926 20	2 50 926 20
	-	2		PE conductive	2 15 926 21	2 25 926 21	2 40 926 21	2 50 926 21
F4.1-I	-	2	JIS10K flange integrated with inlet/outlet connection	PTFE	2 15 826 23	2 25 826 23	2 40 826 23	2 50 826 23
	-	2		PTFE conductive	2 15 826 24	2 25 826 24	2 40 826 24	2 50 826 24
F7.1-I	-	2	PN10 DIN2576 flange integrated with inlet/outlet connection	PTFE	2 15 626 23	2 25 626 23	2 40 626 23	2 50 626 23
	-	2		PTFE conductive	2 15 626 24	2 25 626 24	2 40 626 24	2 50 626 24
F8.1-I	-	2	ANSI 150 RF flange integrated with inlet/outlet connection	PTFE	2 15 126 23	2 25 126 23	2 40 126 23	2 50 126 23
	-	2		PTFE conductive	2 15 626 24	2 25 126 24	2 40 126 24	2 50 126 24
F9.1-I	-	2	PN16 DIN 2278 flange integrated with inlet/outlet connection	PTFE	2 15 926 23	2 25 926 23	2 40 926 23	2 50 926 23
	-	2		PTFE conductive	2 15 926 24	2 25 926 24	2 40 926 24	2 50 926 24

16.5 Back Flushing System (Option codes: BF1, BF2, BF4, BF5)

A pump equipped with the back flushing system (ball lift system) can be emptied along with an inclining discharge line while being installed within the plant. It consists of a bypass-system in the side housings which can be activated by manual valves (code BF1, BF2) or pneumatically (code BF4, BF5).

Open the manual valves (BF1, BF2) by approx. 10mm by turning to the left (Attention: As there is no blocking of the valves, it has to be ensured not to take them out completely). The pump should be kept in operation meanwhile. Slow down the pump slowly and finally stop it.

The drawing below illustrates the flushing system (code BF4, BF5, minimum air pressure 3 bar). By attaching a 4-2-way valve (not included in the delivery), the back flushing system can be activated automatically when cutting off the pump. Side housing O-rings are made of EPDM (code BF1, BF4) or FEP/FKM core (code BF2, BF5).

Appearance of back flushing system

Manual Back Flushing System (BF1, BF2)

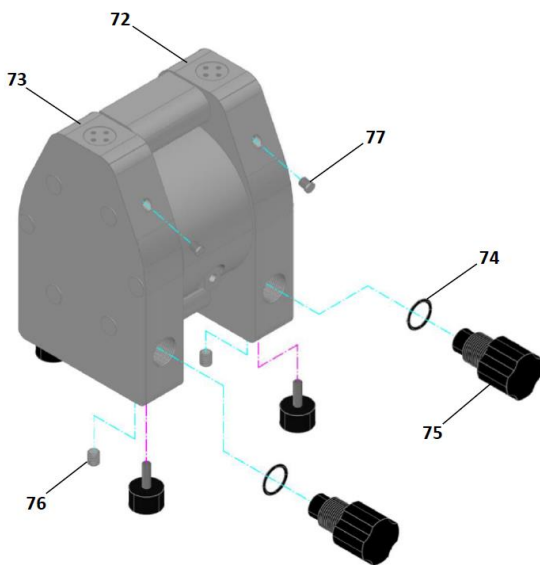

Pneumatic Back Flushing System (BF4, BF5)

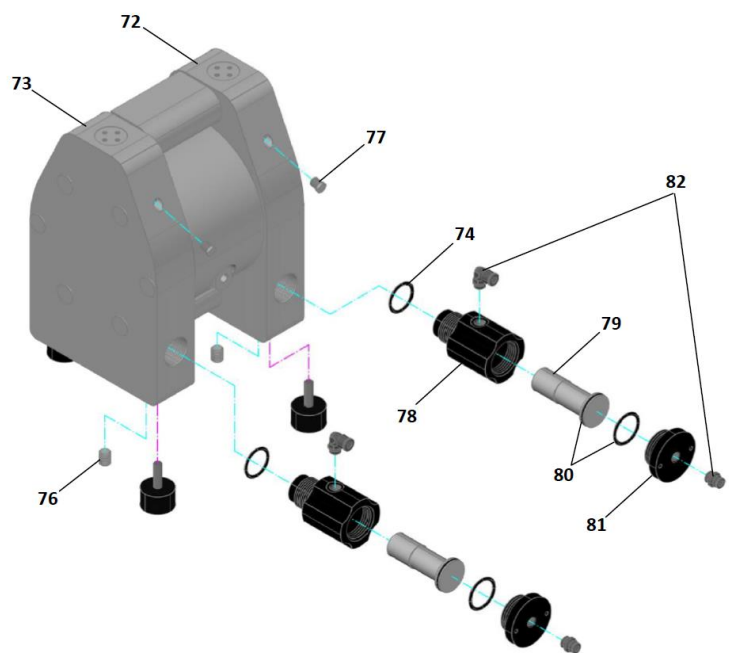

Spare part list, back flushing system

Pump size:				DM 15	DM 25	DM 40	DM 50	
Code:	Item	Q-ty	Part name	Material	Part no.	Part no.	Part no.	Part no.
BF1	72.	1	Pump housing left for BF system	PE	2 15 001 20	2 25 001 20	2 40 001 20	2 50 001 20
				PE conductive	2 15 001 21	2 25 001 21	2 40 001 21	2 50 001 21
				PTFE	2 15 001 23	2 25 001 23	2 40 001 23	2 50 001 23
				PTFE conductive	2 15 001 24	2 25 001 24	2 40 001 24	2 50 001 24
	73.	1	Pump housing right for BF system	PE	2 15 301 20	2 25 301 20	2 40 301 20	2 50 301 20
				PE conductive	2 15 301 21	2 25 301 21	2 40 301 21	2 50 301 21
				PTFE	2 15 301 23	2 25 301 23	2 40 301 23	2 50 301 23
				PTFE conductive	2 15 301 24	2 25 301 24	2 40 301 24	2 50 301 24
	74.	2	O-ring for pump housing	EPDM	2 15 70 08	2 15 70 08	2 40 072 08	2 50 072 08
	75.	2	Drain plug	PE conductive	2 15 066 21	2 25 066 21	2 40 066 21	2 50 066 21
				PTFE conductive	2 15 066 24	2 25 066 24	2 40 066 24	2 50 066 24
	76.	2	Bottom plug	PE	2 15 067 20	2 25 067 20	2 40 067 20	2 50 067 20
				PE conductive	2 15 067 21	2 25 067 21	2 40 067 21	2 50 067 21
				PTFE	2 15 067 23	2 25 067 23	2 40 067 23	2 50 067 23
				PTFE conductive	2 15 067 24	2 25 067 24	2 40 067 24	2 50 067 24
	77.	2	Side plug	PE	2 15 467 20	2 25 467 20	2 40 467 20	2 50 467 20
PE conductive				2 15 467 21	2 25 467 21	2 40 467 21	2 50 467 21	
PTFE				2 15 467 23	2 25 467 23	2 40 467 23	2 50 067 23	
PTFE conductive				2 15 467 24	2 25 467 24	2 40 467 24	2 50 467 24	
BF2	As BF1 but:							
	74.	2	O-ring for pump housing	FEP/FKM core	2 15 70 04	2 15 70 04	2 40 072 04	2 50 072 04
BF4	As BF1 but:							
	78.	2	Piston housing	PE conductive	2 15 266 21	2 25 266 21	2 40 266 21	2 50 266 21
	79.	2	Piston	PTFE	2 15 068 23	2 25 068 23	2 40 068 23	2 50 068 23
	80.	2	Piston and cover O-rings, set	EPDM	2 15 78 08	2 15 78 08	2 40 272 08	2 50 272 08
	81.	2	Piston cover	PE conductive	2 15 168 21	2 25 168 21	2 40 168 21	2 50 168 21
	82.	1	Quick couplings, cpl.	Diverse	2 15 065 00			
BF5	As BF1 but:							
	74.	2	O-ring for pump housing	FEP/FKM core	2 15 70 04	2 15 70 04	2 40 072 04	2 50 072 04

16.6. Compressed air preparation set (Option codes: AF1, AF2)

Compressed air delivered to the pump has to be dry, free from oil and humid (air valve installed inside the central housing do not require lubrication – it works completely oil-free). If you are not sure about the compressed air purity level or the available air is not of good quality, you can install the air preparation set, which consists of:

- Air filter-regulator unit with valve,
- Pressure gauge,
- Hose connectors (quick couplings).

Depending on the size of the pump, there are two available AF Options:

- AF1 – for the pumps from DM 08/10 up to DM 25/125 size;
- AF2 – for the pumps from DM 40/315 up to DM 80/850 size.

AF Option is also available in explosion-proof execution (AF1X or AF2X, with ATEX Certificate) – for more information please contact our Sales Department at office@dellmecc.com.

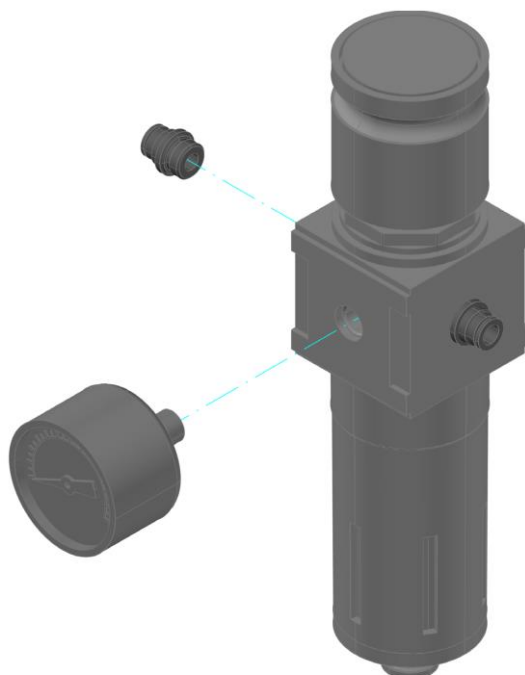

16.7. Drum Pump (Option codes: D1, D2)

Plastic pump from DM 10/25 up to 25/125 size is also available as adapted to empty drum and IBC containers. As presented on the below pictures, additional equipment consists of:

- Special inlet connection [83], with BSPP thread (internal) fitted to the suction drum pipe.
- Pump support [84]
- Drum pipe [85], with BSPP thread (external).

Standard Plastic Series Pump can be also re-assembled into the Drum Pump, by adding Items [84], [85] and by replacing standard inlet connection with Item [83].

Standard inlet connection (left) and Drum Option inlet connection (right) comparison

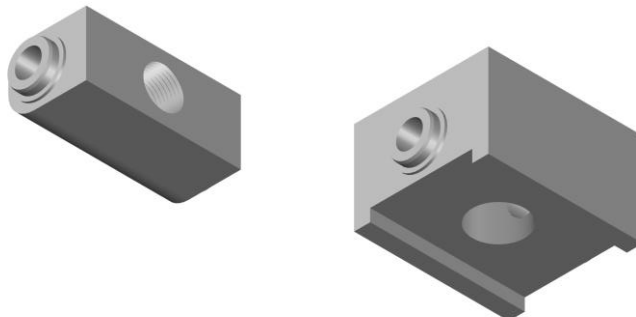

Appearance of the Plastic Pump with Drum Option

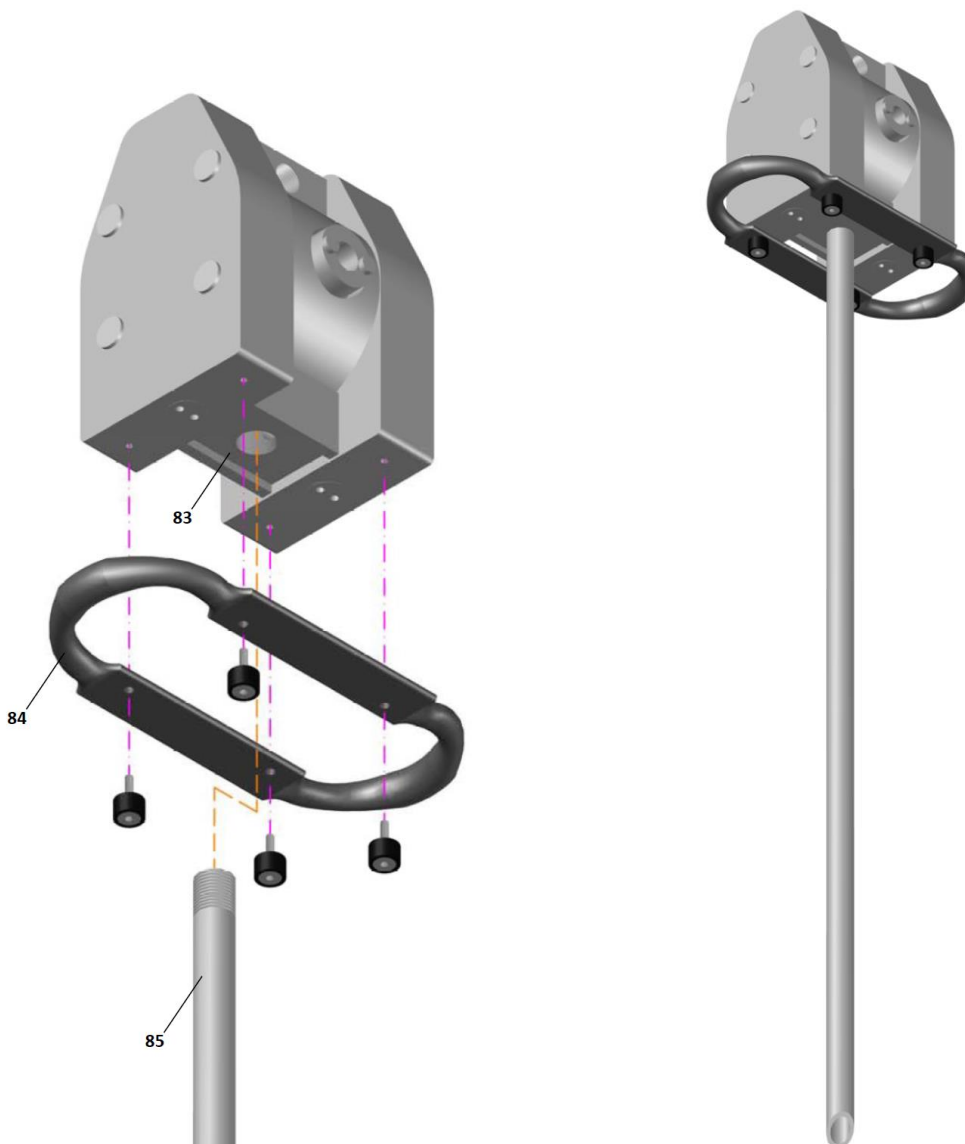

Spare part list for the Plastic Pump with Drum Option

Pump size:				DM 10	DM 15	DM 25	
Code	Item	Quantity	Part name	Material	Part No.		
D1	83.	1	Drum pipe inlet connection	PE	2 10 33 20	2 15 33 20	2 25 33 20
				PE conductive	2 10 33 21	2 15 33 21	2 25 33 21
				PTFE	2 10 33 23	2 15 33 23	2 25 33 23
				PTFE conductive	2 10 31 24	2 15 33 24	2 25 33 24
	84.	1	Pump support	AISI 304	2 10 98 50	2 15 98 50	2 25 98 50
85.	1	Drum pipe	PP (for PE Pumps only)	2 10 96 28	2 15 96 28	2 25 96 28	
D2			as in D1, but:				
	85	1	Drum pipe	AISI 316L (for PTFE, PE cond. and PTFE cond. Pumps)	2 10 96 53	2 15 96 53	2 25 96 53

The standard length of drum pipe is 1000 mm, but specific order can be made to fit any container size (e.g., 800 mm, 1200 mm).

Standard Plastic PE Pump is equipped with PP (polypropylene) pipe. PTFE Pump and also ATEX executions (PE conductive and PTFE conductive) are equipped with AISI 316L pipe. In the case of other pipe material execution requirement, please contact us at: office@dellmeco.com.

16.8 High Pressure System (Option codes: HPM, HPS)

DELLMECO diaphragm pumps can be fitted with High Pressure option. It is a very compact unit that can be mounted directly to the filter press. It has been designed for charging filter presses with chemical wastes and special sludge. An external pressure booster doubles the delivery pressure.

Filter presses with DELLMECO HP pump

Automatic adaptation

When slurry is transferred to a chamber filter press, first the chambers get filled while the pressure tends to zero. Under the increasing filling-level the solids assemble at the filter cloths. This requires a pressure that continuously rises with the increasing content of solids. Under a constant flow quantity the pressure would rise extremely fast.

The drive of the HP pump by compressed air causes a diminution of the flow quantity according to the increasing counter-pressure in the filter press. This produces a soft filtration curve, automatically self-regulating according to the filling level of the filter press. This is independent from the properties of the slurry. No pressure tank nor pressure transmitter nor speed control are required. The complete HP pump works without electric energy.

End of filtration process

When the filter press is filled with the solids so far that no more slurry can be taken up, the pressing period is terminated. The air operation of the DELLMECO pumps then reduces the flow rate to zero while the outlet pressure holds the required level compressing the filter cake. Excellent results in drying are obtained. At the end of the pressing period the pump simply stops.

Pressure adjustment

The required pressure in the filter press is comfortably adjusted by the height of the air pressure supplying the charging station. For a required pressure of 12 bar the HP pump has to be supplied with 6 bar when the pump with a pressure transmission of 1:2 is applied. In the case that higher pressures are necessary or there is only a lower air pressure available, the HP pump with 1:4 transmission can be applied.

Low air consumption

The charging stations need the maximum air quantity only during the filling period. The more the press is filled, the more slowly the pump works. So the air consumption slowly reaches zero during progressing filtration.

There are two types of boosters available:

- 1) High Pressure **HPM** Option – with Metalwork booster (Metalwork booster applicable for ATEX EEx II 2GD)
- 2) High Pressure **HPS** Option – with SMC booster (version with ATEX EEx II 3GD – available only for demand).

Plastic Series Pumps with HPM or HPS Option – from DM 15/55 to DM 50/565 Pump sizes

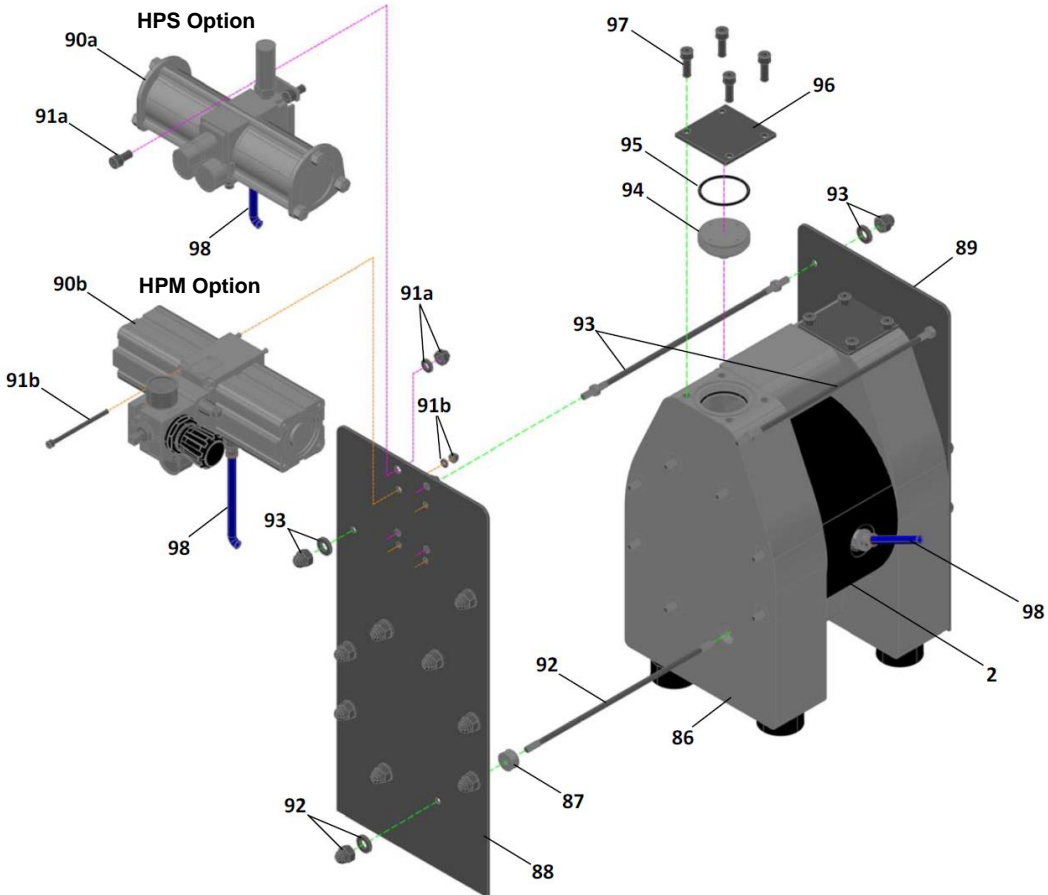

Plastic Series Pump DM 80/850 with HPS Option (double SMC booster only!!!)

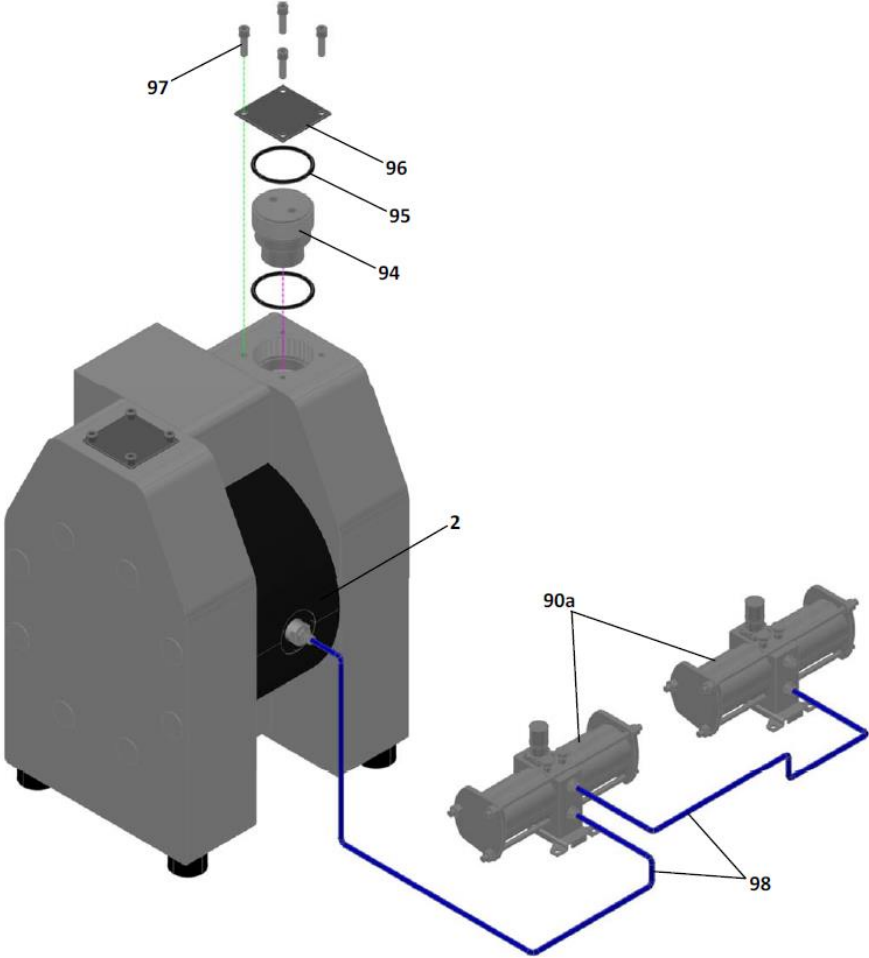

Spare part list, Plastic Series Pumps with High Pressure Option

				Pump size	DM 15/55	DM 25/125	DM 40/315	DM 50/565	DM 80/850
Code	Item	Pcs.	Description	Material	Part No.	Part No.	Part No.	Part No.	Part No.
HP	2	1	Central housing ^(*)	PE conductive	1 15 10 21	1 25 10 21	1 40 10 21	1 50 10 21	1 80 10 21
	86.	2	HP option pump housing (with threaded inserts)	PE	2 15 601 20	2 25 601 20	2 40 601 20	2 50 601 20	2 80 601 20
				PE conductive	2 15 601 21	2 25 601 21	2 40 601 21	2 50 601 21	2 80 601 21
				PTFE	2 15 601 23	2 25 601 23	2 40 601 23	2 50 601 23	2 80 601 23
				PTFE conductive	2 15 601 24	2 25 601 24	2 40 601 24	2 50 601 24	2 80 601 24
	87.	12/16 ⁽¹⁾	HP Option side housing sleeve	PE	2 15 263 20	2 25 263 20	2 40 263 20 ⁽¹⁾	2 50 263 20 ⁽¹⁾	
				PE conductive	2 15 263 21	2 25 263 21	2 40 263 21 ⁽¹⁾	2 50 263 21 ⁽¹⁾	
				PTFE	2 15 263 23	2 25 263 23	2 40 263 23 ⁽¹⁾	2 50 263 23 ⁽¹⁾	
				PTFE conductive	2 15 263 24	2 25 263 24	2 40 263 24 ⁽¹⁾	2 50 263 24 ⁽¹⁾	
	88.	1	Distance plate short	AISI 304	2 15 164 50	2 25 164 50	2 40 164 50	2 50 164 50	
	89.	1	Distance plate long	AISI 304	2 15 264 50	2 25 264 50	2 40 264 50	2 50 264 50	
	90a.	1 / 2 ⁽²⁾	Air pressure booster HPS, complete (with manometers, couplings)	Diverse	9 15 64 00	9 25 64 00	9 25 64 00	9 50 64 00	9 50 64 00 ⁽²⁾
	90b.	1	Air pressure booster HPM, complete (with manometers, couplings)	Diverse	9 15 964 00	9 15 964 00	9 40 964 00	9 40 964 00	
	91a.	1	SMC booster mounting set	AISI 304	9 15 S42 50	9 25 S42 50	9 25 S42 50	9 50 S42 50	
	91b.	1	Metalwork booster mounting set	AISI 304	9 15 M42 50	9 15 M42 50	9 40 M42 50	9 40 M42 50	
	92.	1	HP Option housing bolts, complete (with nuts and washers)	AISI 304	1 15 45 50	1 25 45 50	1 40 45 50 ⁽⁴⁾	1 50 45 50	
	93.	2	HP Option distance plate bolts, complete (with nuts and washers)	AISI 304	1 15 464 50	1 25 464 50	1 40 464 50	1 50 464 50	
	94.	2	HP Option upper plug	PE	2 15 655 20	2 25 655 20	2 40 655 20	2 50 655 20	2 80 655 20
				PE conductive	2 15 655 21	2 25 655 21	2 40 655 21	2 50 655 21	2 80 655 21
				PTFE	2 15 655 23	2 25 655 23	2 40 655 23	2 50 655 23	2 80 655 23
		PTFE conductive		2 15 655 24	2 25 655 24	2 40 655 24	2 50 655 24	2 80 655 24	
95.	2	HP Option upper plug O-ring, external	EPDM	2 15 278 08	2 25 278 08	2 40 278 08	2 50 278 08	2 80 278 08	
			NBR	2 15 278 10	2 25 278 10	2 40 278 10	2 50 278 10	2 80 278 10	
96.	2	Plate for upper plug	AISI 304	2 15 464 50	2 25 464 50	2 40 464 50	2 50 464 50	2 80 464 50	
97.	1	Upper plug plate screw, set	AISI 304	2 15 564 50	2 25 564 50	2 40 464 50	2 50 464 50	2 80 464 50	
98.	1	Air supply hose with connections	Diverse	2 15 592 60	2 25 592 60	2 40 592 60	2 50 592 60	2 80 592 60	

(*) – central housing material for HP Option is always PE conductive (both for non-ATEX and ATEX versions)

Torque values for housing bolts, HP Option [Nm]:					
Pump's material execution	Size of the Plastic Pump with HPM or HPS Option				
	DM 15	DM 25	DM 40	DM 50	DM 80
PE., PN., PT.	13	18	22	26	24
RE., RN., RT.					
TE., TN., TT.	12	16	20	23	22
ZE., ZN., ZT.					

Appearance and dimensions of high pressure system (Plastic Pump with HPS option)

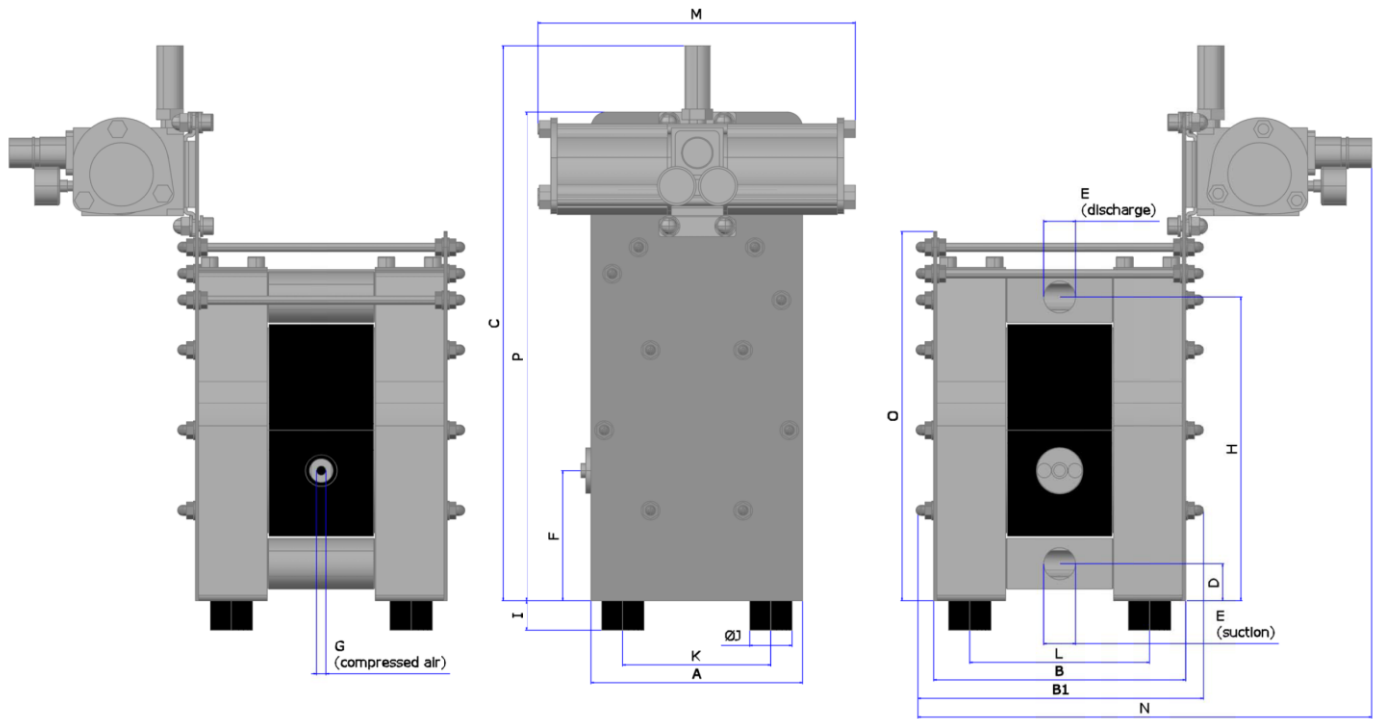

Appearance and dimensions of high pressure system (Plastic Pump with HPM option)

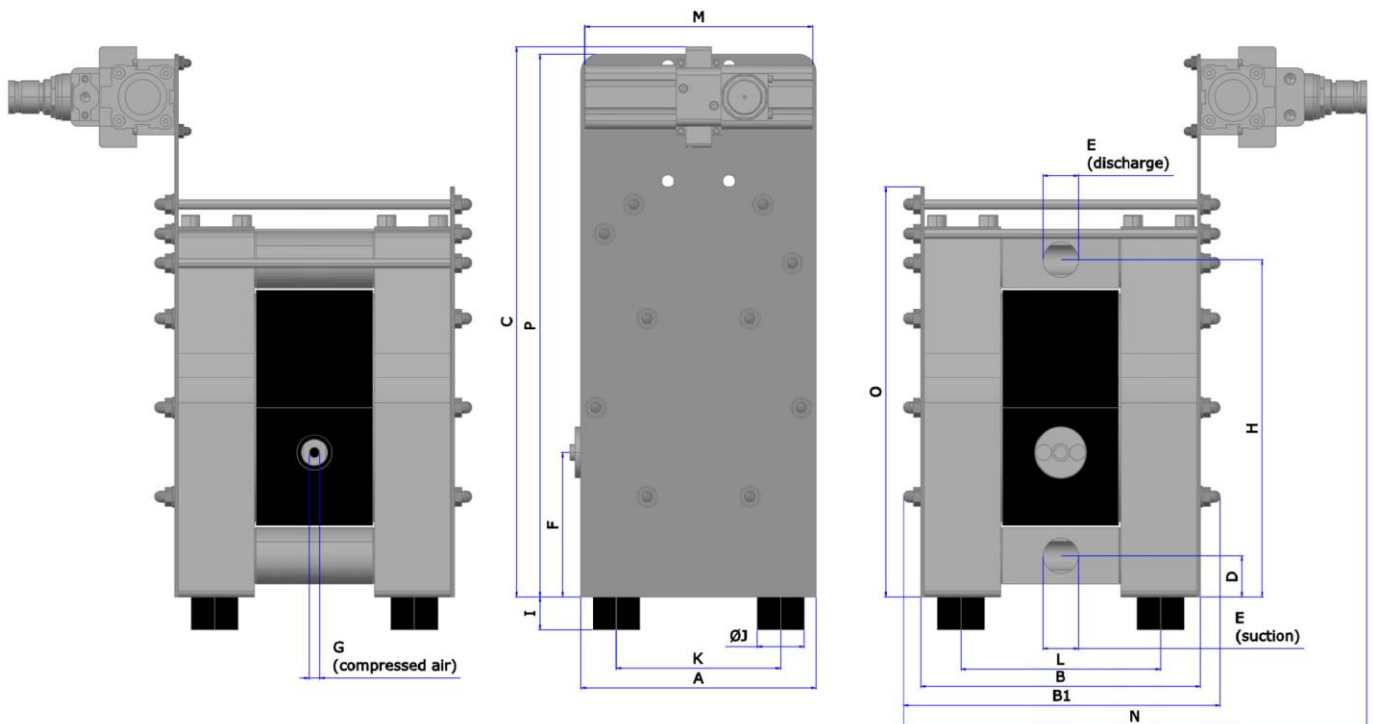

Pump size	A	B	B1	C	D	E	F	G	H	I	ØJ	K	L	M	N	O	P
DM 15/55 ...-HPS	150	183	208	376	25	G 1/2"	92	R 1/4"	217	18	30	112	136	150	309	253	333
DM 15/55 ...-HPM	150	183	208	337	25	G 1/2"	92	R 1/4"	217	18	30	112	136	194	337	253	333
DM 25/125 ...-HPS	200	238	272	525	35	G 1"	123	R 1/4"	287	28	40	140	170	300	431	349	462
DM 25/125 ...-HPM	200	238	272	468	35	G 1"	123	R 1/4"	287	28	40	140	170	194	394	349	462
DM 40/315 ...-HPS	270	318	351	656	42	G 1 1/2"	123	R 1/2"	388	30	60	190	227	300	510	500	600
DM 40/315 ...-HPM	270	318	351	559	42	G 1 1/2"	123	R 1/2"	388	30	60	190	227	290	518	500	600
DM 50/565 ...-HPS	350	393	442	754	45	G 2"	160	R 1/2"	485	30	60	270	282	405	633	560	730
DM 50/565 ...-HPM	350	393	442	704	45	G 2"	160	R 1/2"	485	30	60	270	282	290	600	560	730

Performance curves

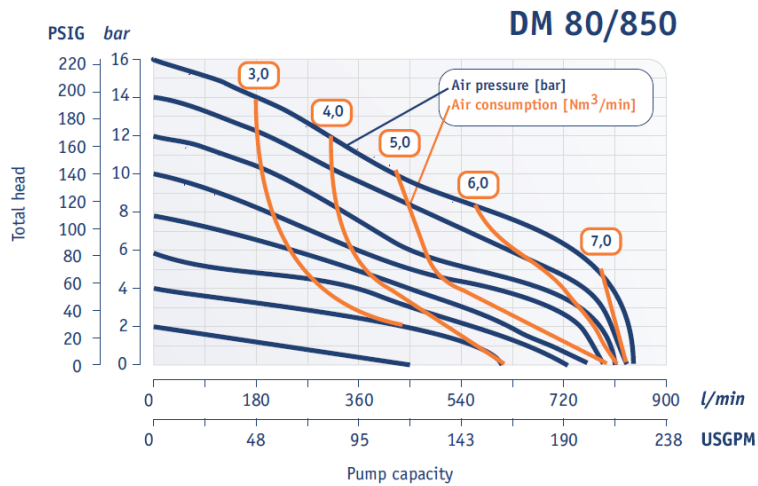
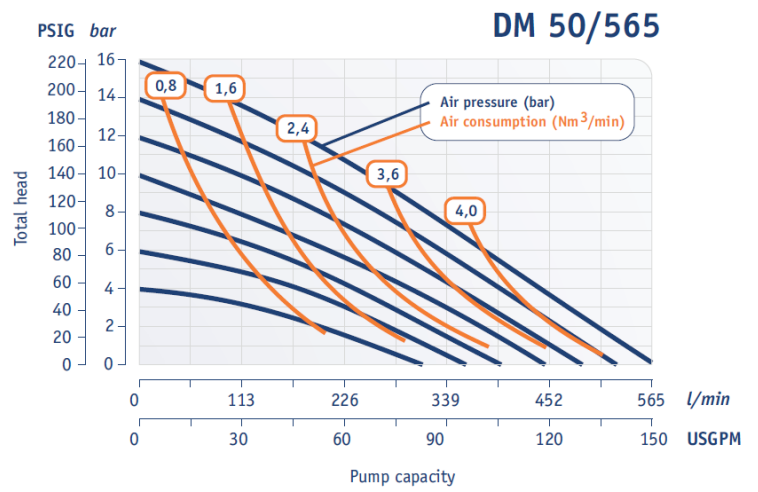
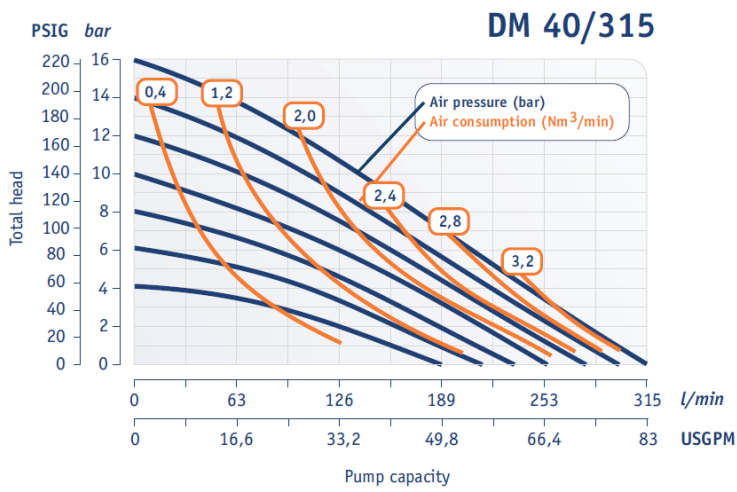
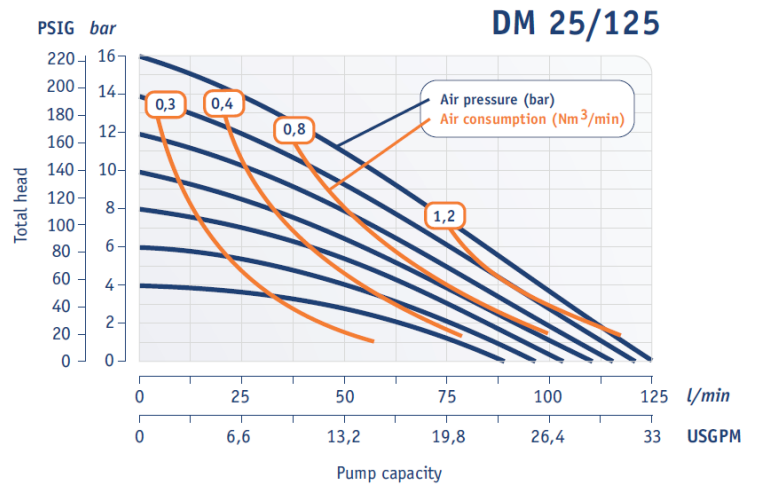
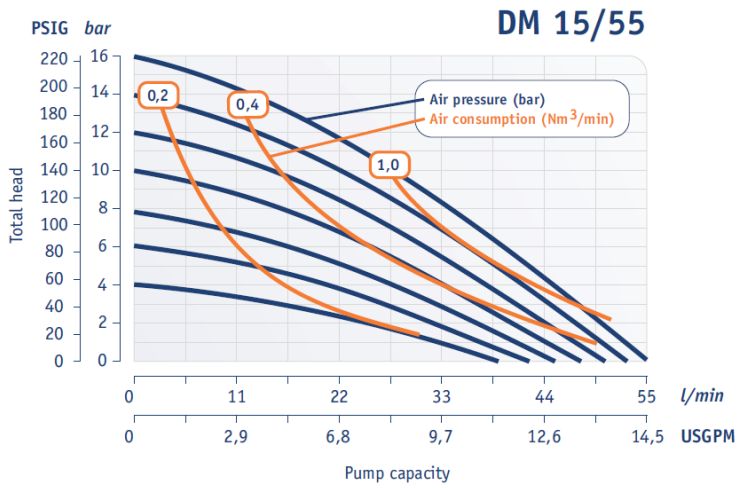

16.9 Pump with solenoid valve (Option code MV)

DELLMECO plastic pump with the MV option replaces the standard air valve with a solenoid air valve. This enables media to be delivered in precise and constant volumes for such applications as found in the chemical industry.

Pump with MV Option is fitted with a 5/2 electro-pneumatic monostable NAMUR solenoid valve. When the solenoid is unpowered and the pump is delivered with compressed air (air supply valve is opened), one chamber within the pump is pressurized with air whilst the opposite chamber is discharged. When electric power is applied to the coil (24 VDC), the solenoid re-pressurizes the discharged chamber and the opposite chamber is being charged. An appropriate timer unit is required to control the coil (electric signal has to be initiated and disrupted alternately).

By alternatively turned on and off the electric signal supplied to the solenoid valve (quantity of electric signals can be defined per specified unit time – e.g., 30 seconds, 1 minute, 1 hour etc.), MV Option enables the pump unit to run like a standard DELLMECO pump with precise dosing of the liquid to the system and without contaminating the exhausted air (no lubrication is needed).

Solenoid valve is mounted outside the pump – directly on the central housing – which is specially designed for this purpose.

Appearance of the Plastic Pump with MV Option

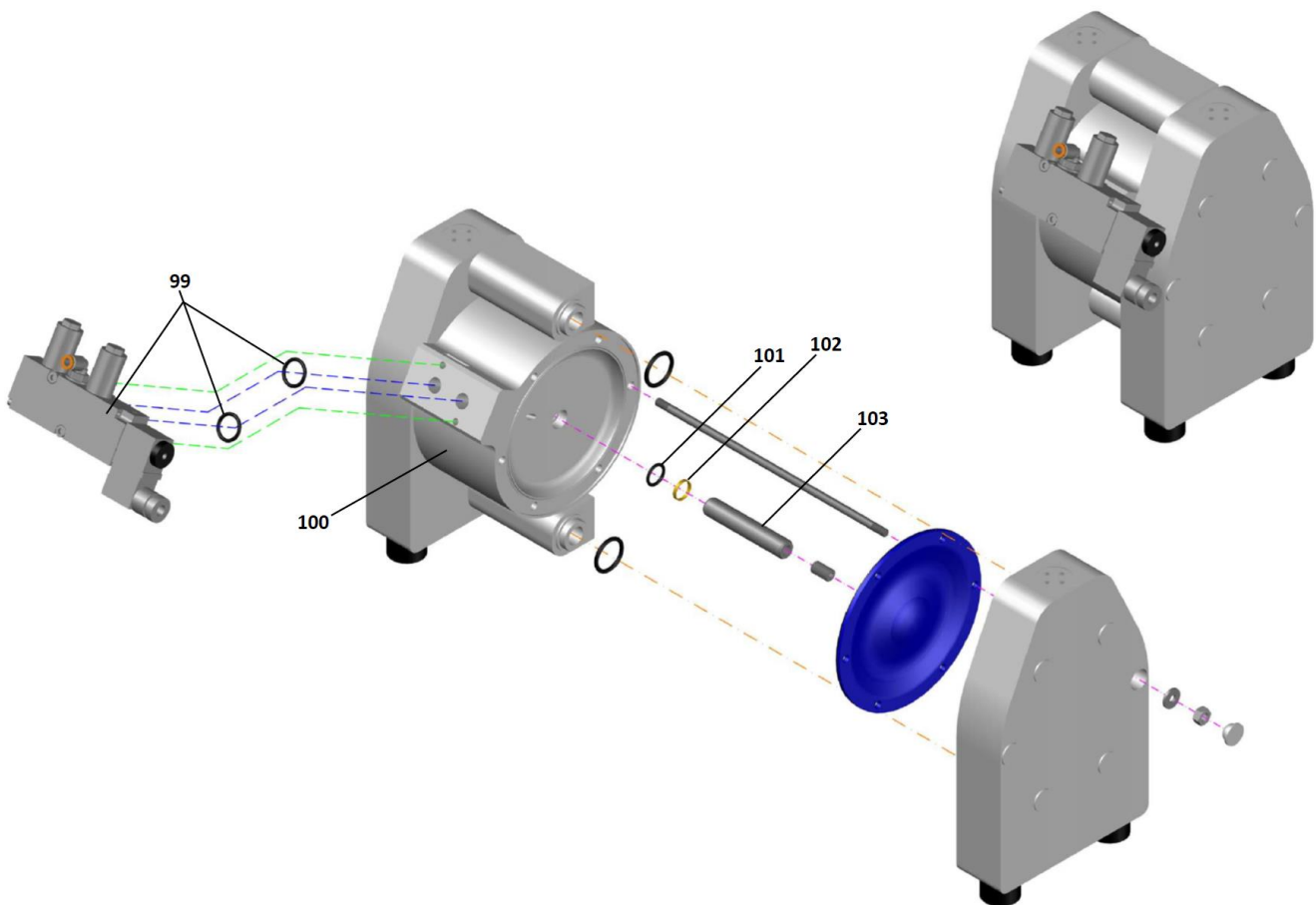

Spare part list for the Plastic Pump with MV Option^(*)

				Pump size:	DM 08/10	DM 10/25	DM 15/55	DM 25/125	DM 40/315
Code	Item	Q-ty	Description	Material	Part no.	Part no.	Part no.	Part No.	Part No.
MV	99.	1	Central housing, MV Option	PE	1 08 410 20	1 10 410 20	1 15 410 20	1 25 410 20	1 40 410 20
				PE conductive	1 08 410 21	1 10 410 21	1 15 410 20	1 25 410 21	1 40 410 21
	100.	1	External air valve for MV Option, complete ^(**)	Diverse	1 08 720 00	1 08 720 00	1 08 720 00	1 08 720 00	1 40 720 00
	101.	2/4 ^(a)	Diaphragm shaft O-ring	NBR	1 08 82 10		1 15 85 10	1 25 85 10 ^(a)	1 40 85 10
	102.	2	Diaphragm shaft gasket	PTFE-PPS ^(b) / PE	1 08 90 18 ^(b)		1 15 85 22	1 25 85 22	1 40 85 22
103.	1	Diaphragm shaft for MV Option	AISI 304	1 08 124 50		1 15 40 50	1 25 40 50	1 40 40 50	

^(*) – spare parts not included in the above chart are the same as for standard Plastic Series Pump (internal air valve)

^(**) – MV Option Pump with ATEX certificate available on demand

16.10 Pump for transferring powders (Option code P)

DELLMECO Pump with "P" Option can also be used to transfer dry powders more quickly, cleanly and at a fraction of the cost than many other system. Thanks to that you can replace manual powder transfer process with the following advantages:

- Airborne contamination reducing (powders can be transferred directly in a closed system)
- Pump can be easily moved from site to site (also available trolley – as a "T" Option)
- Economic and simple system (the opposite of large and complex systems).

Pump is applicable for transferring fine powders up to 800 kg/m^3 (50 lb/ft^3). In addition, powder to be pumped has to be without tendency for sticking/caking and free of moisture.

A reliable, efficient and trouble-free transfer is possible for the following exemplary substances:

- Various types of dry food
- Limestone
- Pharmaceuticals
- Talcum
- Expanded mica
- Silicones and silicas
- Carbon black
- Acrylic resins.

Appearance of the Plastic Pump with Powder Option

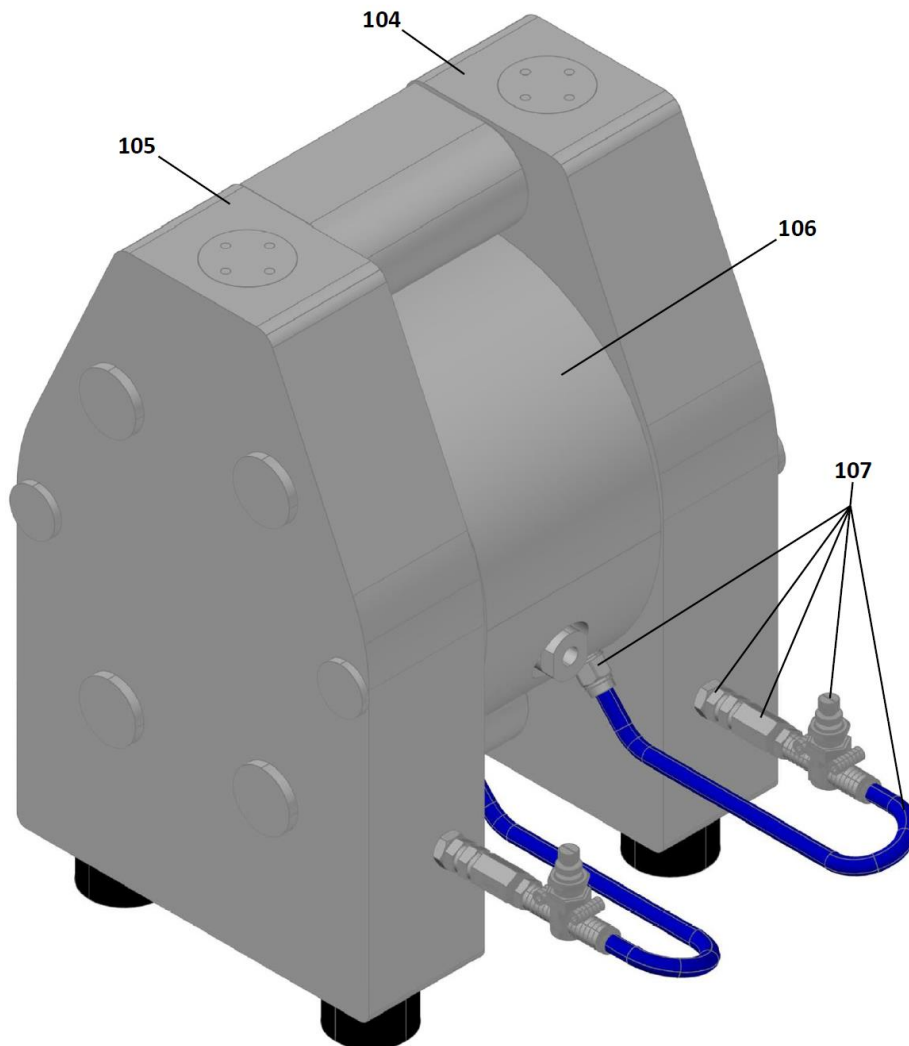

Spare part list for the Plastic Pump with Powder Option

				Pump size:							
				DM 10/25	DM 15/55	DM 25/125	DM 40/315	DM 50/565	DM 80/850		
Code	Item	Q-ty	Description	Material	Part No.	Part no.	Part No.	Part No.	Part No.	Part No.	Part No.
P	104.	1	Left side housing for Powder Option	PE	2 10 401 20	2 15 401 20	2 25 401 20	2 40 401 20	2 50 401 20	2 80 401 20	
				PE cond.	2 10 401 21	2 15 401 21	2 25 401 21	2 40 401 21	2 50 401 21	2 80 401 21	
				PTFE	2 10 401 23	2 15 401 23	2 25 401 23	2 40 401 23	2 50 401 23	2 80 401 23	
				PTFE cond.	2 10 401 24	2 15 401 20	2 25 401 24	2 40 401 20	2 50 401 24	2 80 401 24	
	105.	1	Right side housing for Powder Option	PE	2 10 501 20	2 15 501 20	2 25 501 20	2 40 501 20	2 50 501 20	2 80 501 20	
				PE cond.	2 10 501 21	2 15 401 21	2 25 401 21	2 40 401 21	2 50 501 21	2 80 501 21	
				PTFE	2 10 501 23	2 15 401 23	2 25 501 23	2 40 401 23	2 50 501 23	2 80 501 23	
				PTFE cond.	2 10 501 24	2 15 401 20	2 25 401 24	2 40 401 20	2 50 401 24	2 80 501 24	
	106.	1	Central housing for Powder Option	PE	1 10 410 20	1 15 410 20	1 25 410 20	1 40 410 20	1 50 410 20	1 80 410 20	
				PE conductive	1 10 410 21	1 15 410 20	1 25 410 21	1 40 410 21	1 50 410 21	1 80 410 21	
	107.	2	Non-return valve for Powder Option, complete	Diverse	1 10 720 00	1 15 720 00	1 25 720 00	1 40 720 00	1 50 720 00	1 80 720 00	

16.11. Sleeve with Split Connections (option code S)

Plastic pumps from DM 10/25 up to DM 40/315 size can be converted from a double-acting air-driven diaphragm pump into two separated single-acting ones. Standard inlet/outlet connections with one suction and one discharge are then exchanged for inlet/outlet connections with separated suction and discharge connections for both pump chambers. Owing to this, you obtain pump ready to transfer two different liquids with liquid streams in 1:1 ratio.

Below drawing shows difference between the standard inlet/outlet connection (left side) and the split inlet/outlet connection – “S” Option (right side). Nominal twin-port size is the same as in standard connection (e.g., for DM 10/25 Plastic Pump all connections are BSPP 3/8”). O-ring situated between halves ensures stable connection and allows to rotate connections in different directions.

Standard in-/outlet connection

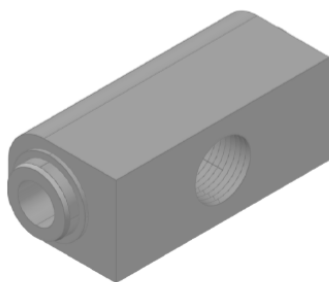

Split in-/outlet connection

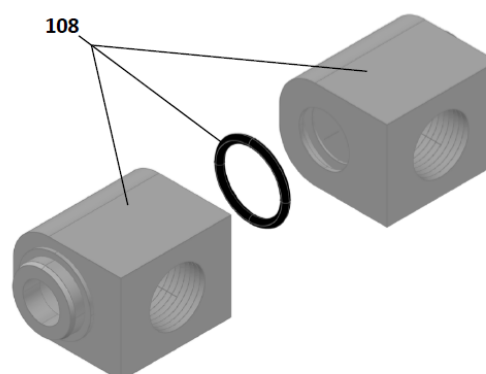

Spare part list, split connections

				Pump size:				
				DM 10	DM 15	DM 25	DM 40	
Code	Position	Quantity	Description	Material	Part no.	Part no.	Part no.	Part no.
S	108.	2	Sleeve with split connections (O-ring included)	PE	2 10 31 20	2 15 31 20	2 25 31 20	2 40 31 20
				PE conductive	2 10 31 21	2 15 31 21	2 25 31 21	2 40 31 21
				PTFE	2 10 31 23	2 15 31 23	2 25 31 23	2 40 31 23
				PTFE conductive	2 10 31 24	2 15 31 24	2 25 31 24	2 40 31 24

16.12. Inlet/outlet stainless steel connections (AISI 316L, option code SSC)

Plastic pumps from DM 08/10 up to DM 40/315 size can be equipped with AISI 316L inlet/outlet connections equipped with the same size of thread (BSPP). This solution ensures longer thread life in the case of frequent assembling/disassembling the inlet/outlet hoses.

Standard in-/outlet connection

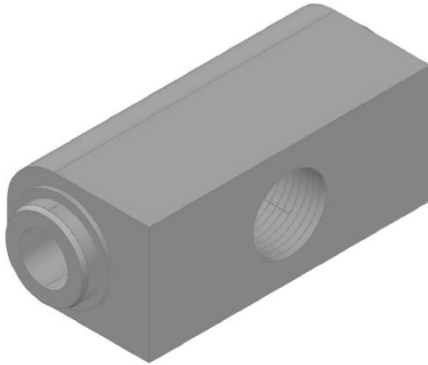

AISI 316L in-/outlet connection

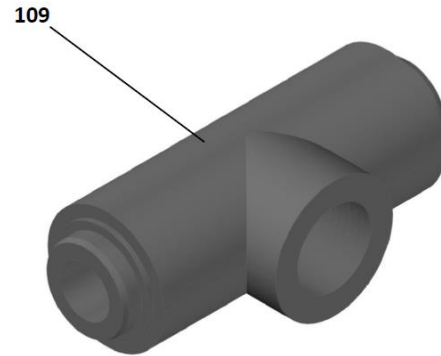

Spare part list, in-, outlet stainless steel connections

					Pump size:				
					DM 08/10	DM 10/25	DM 15/55	DM 25/125	DM 40/315
Code	Position	Q-ty	Description	Material	Part no.				
SSC	109.	2	Stainless steel inlet/outlet connection	AISI 316L	2 08 35 53	2 10 35 53	2 15 35 53	2 25 35 53	2 40 35 53

Comparison of the Plastic Pumps: standard (left view) and with SSC Option (right view)

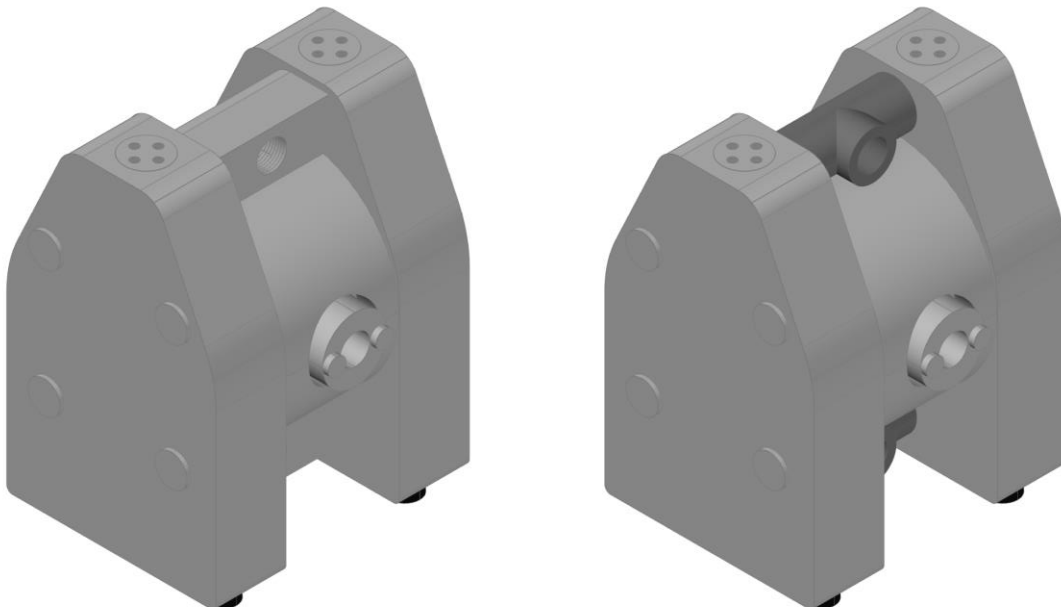

NOTE: Inlet/outlet sealing set is the same size for both standard and SSC Option connections.

16.13. Trolley for pumps (Option code T)

Using the trolley makes your DELLMECO Plastic Series Pump mobile and easy to transport – especially in the case of heavy pumps and awkward workpieces (additional inlet/outlet hoses, air-filter regulators, valves, boosters etc.). Trolley is available for the entire range of Plastic Series Pumps – from DM 08/10 up to 80/850 size. Trolley is made completely from AISI 304, except the wheel sets (4 wheel sets per 1 trolley). Pump trolley is also available for ATEX area (special wheel sets with conductive rolling elements).

Wheel sets can be customized on the demand (different material of execution, dimensions etc.). Standard execution refers to the non-ATEX wheel sets.

When the pump is being ordered together with trolley option (e.g., **DM 25/125 PTT-T**), intervals between the brackets for fixing will be adjusted to the ordered pump's model – here: DM 25/125 PTT. In the case of ordering trolley for the pump already bought, model of the pump has to be specified, in order to deliver the trolley with proper brackets that allow for trouble-free installing the pump on the purchased trolley. Fixing brackets do not apply to DM 80/850 Pump size (this pump is fixed directly to the trolley plate, without using brackets).

Appearance of the Plastic Pump on Trolley

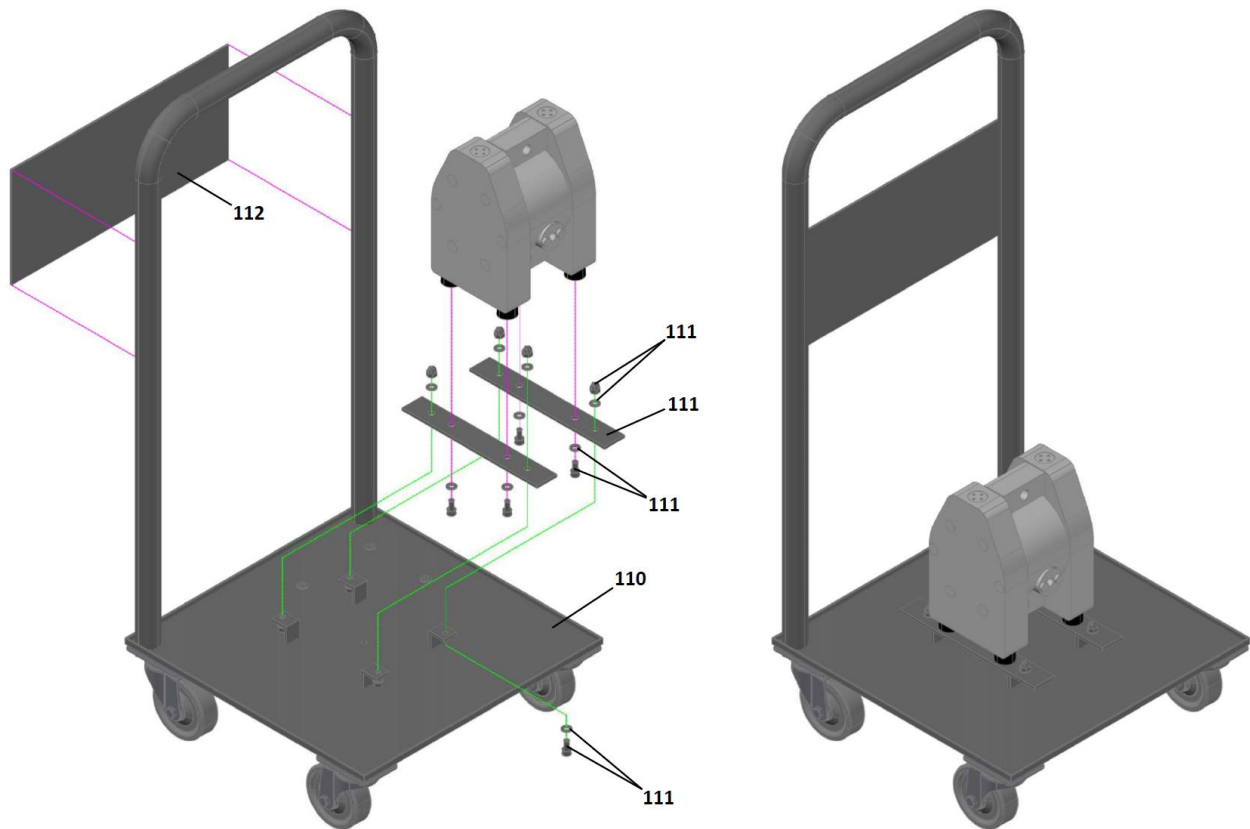

Spare part list for Trolley Option

					Pump size:							
					DM 08/10	DM 10/25	DM 15/55	DM 25/125	DM 40/315	DM 50/565	DM 80/850	
Code	Position	Q-ty	Description	Material	Part no.	Part no.	Part no.	Part no.	Part no.	Part no.	Part no.	
T	110.	1	Trolley with wheels	AISI 316	2 08 193 00	2 10 193 00	2 15 193 00	2 25 193 00	2 40 193 00	2 50 193 00	2 80 193 00	
			ATEX trolley, cpl.	AISI 316	2 08 293 00	2 10 293 00	2 15 293 00	2 25 293 00	2 40 293 00	2 50 293 00	2 80 293 00	
	111.	1	Pump fixing set (brackets, nuts washers, bolts)	AISI 316	2 08 393 52	2 10 393 52	2 15 393 52	2 25 393 52	2 40 393 52	2 50 393 52	2 80 393 52	
	112.	1	Vertical plate (optional)	AISI 316	1 08 493 52						1 80 493 52	

For the pumps from DM 08/10 up to DM 50/565 size, maximum dimensions of the trolley are: 480x480x1050 mm (length x width x height). In the case of DM 80/850 Plastic Series Pump, maximum dimensions of the trolley are: 650x650x1050 (length x width x height).

NOTE: Specified dimensions may change due to final execution of the pump and/or trolley (optional equipment, material and capacity of the wheels, handle execution etc.).

16.14. Inlet/outlet connections with BSPT thread (Option code BSPT)

Although all DELLMECO Plastic Series Pumps from DM 08/10 up to 50/565 size (DM 80/850 Pumps are standardly equipped with DIN PN10/16 flange connections, but 3" BSPP is also possible) are equipped with internal BSPP thread (British Standard Pipe Parallel thread with angle 55° and constant diameter, denoted by the letter "G"), it is possible to order the Plastic Series Pump with BSPT internal thread (British Standard Pipe Taper thread with angle 55°, whose diameter increases or decreases along the length of the thread) also denoted by the symbol R_c (internal taper). BSPT is the most popular thread in the UK & Australia.

16.15. Inlet/outlet connections with NPT thread (Option code NPT)

DELLMECO Plastic Series Pumps from DM 08/10 up to 50/565 size are equipped with internal BSPP thread (as described in the Chapter 16.13), but it is also possible to order the Plastic Series Pump with NPT (National Pipe Taper a.k.a. American National Standard Taper Pipe Thread – a taper thread that has 60° thread angle) internal thread. NPT is used for sealing, often without any thread sealant and for connections in nearly every type of service. It is the most common thread for pipes in North America.

16.16. Air valve (thread-mounted) execution material option and spare parts kit set (AVD)

DELLMECO Plastic Series Pumps from DM 08/10 up to 80/850 size are equipped with PET/NBR air valve (standard execution), where the main parts – cylinder, piston, side covers – are made from PET, while the external O-rings (Item No. 15 in the spare parts list) are made from NBR material. Optionally, the air valve can be offered as PET/FKM version (optional execution), where the external O-rings are made from FKM (a.k.a. FPM, or Viton®.) instead of NBR material (main parts material execution remains the same – PET).

Appearance of the specific sizes of an air valve for DELLMECO Plastic Series Pumps is presented below:

- A. Air valve "08" size (part no.: 1 08 020 31, PET/NBR and 1 08 020 32, PET/FKM), applicable for DM 08/10 ... and DM 10/25... Pump models:**

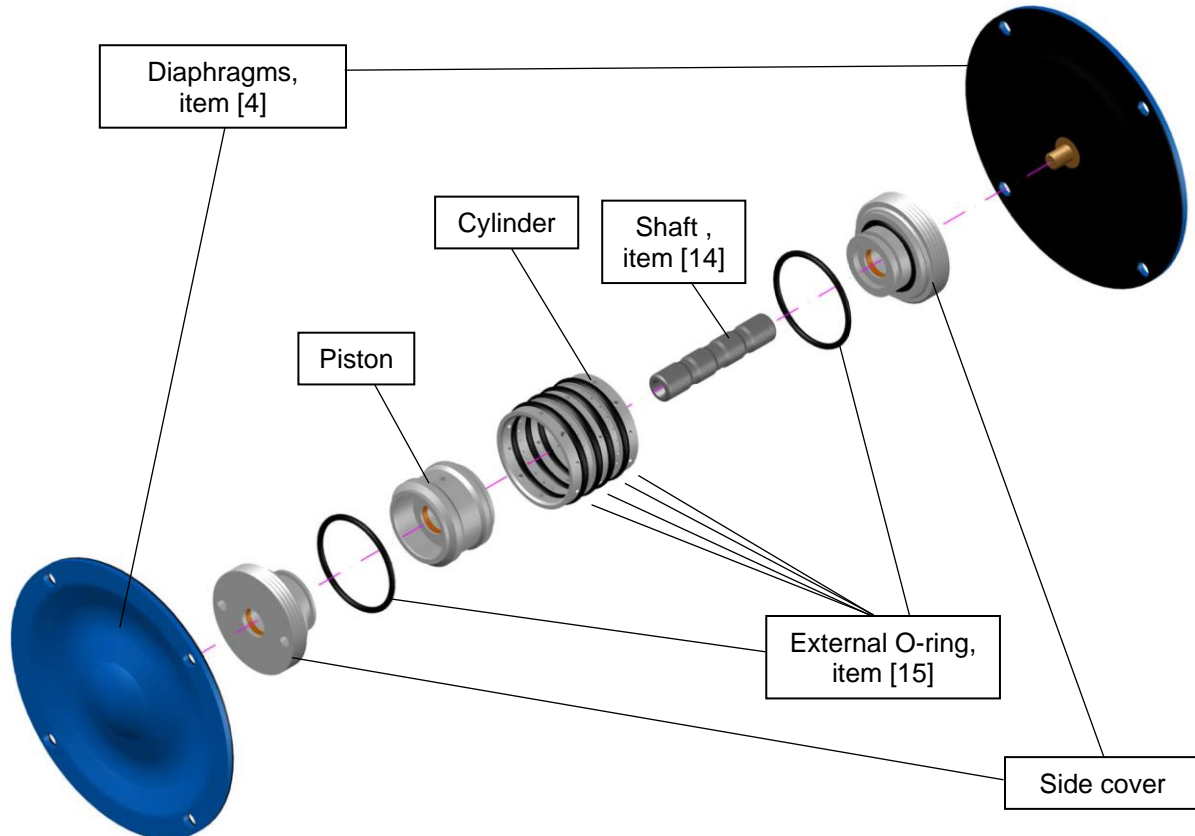

The distinguishing feature of the smallest "08" air valve is that the main shaft (made from AISI 304 material) is a common element for both diaphragms and air valve unit. Each diaphragm ("08" and "10" sizes only!) has external thread that allows to assemble them directly on the main shaft. The remaining sizes of air valves have two separated shafts – air valve shaft (made from PET) and diaphragm shaft (made from AISI 304), as presented below.

- B. Air valve “15” size (part no.: 1 15 020 31, PET/NBR and 1 15 020 32, PET/FKM), applicable for DM 15/55 ... and DM 25/125... Pump models; air valve “40” size (part no.: 1 15 020 31, PET/NBR and 1 15 020 32, PET/FKM), applicable for DM 40/315 ... and DM 50/565... Pump models:**

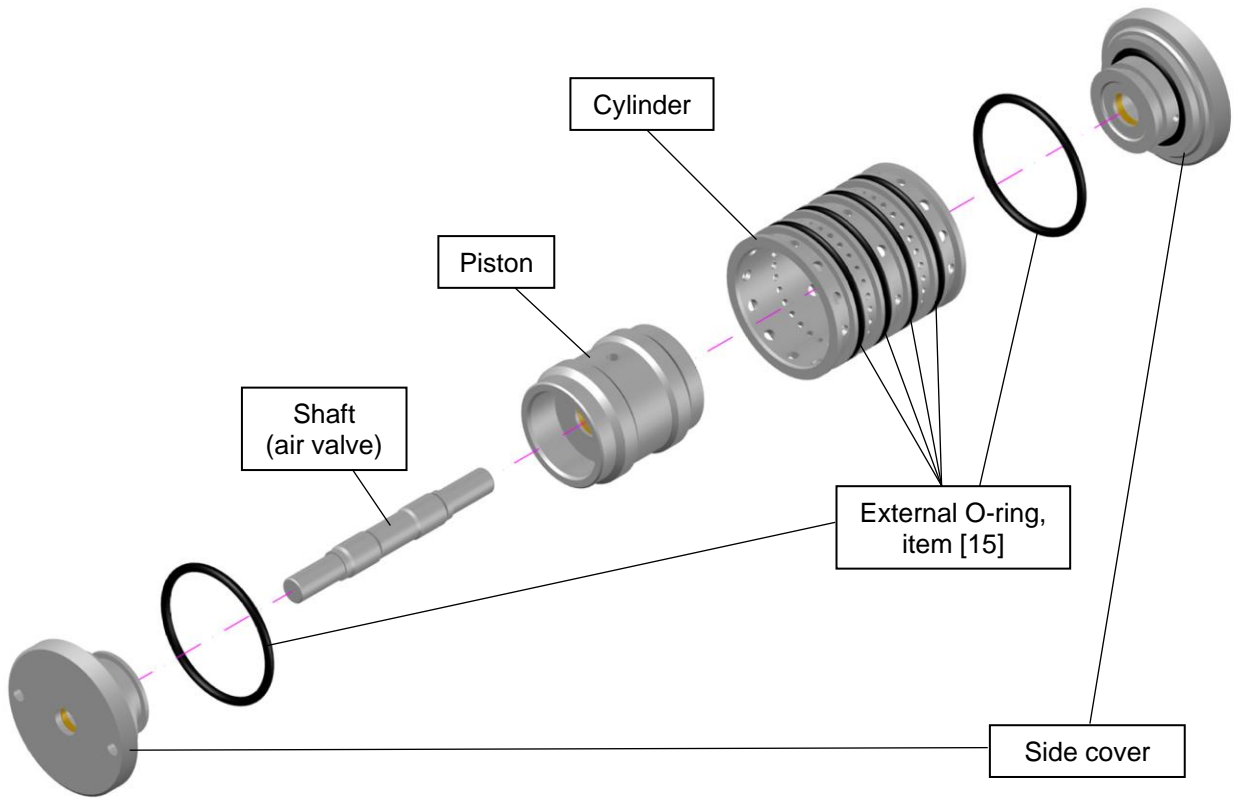

- C. Air valve “80” size (part no.: 1 80 020 31, PET/NBR and 1 80 020 32, PET/FKM), applicable for DM 80/850 ... Pump models:**

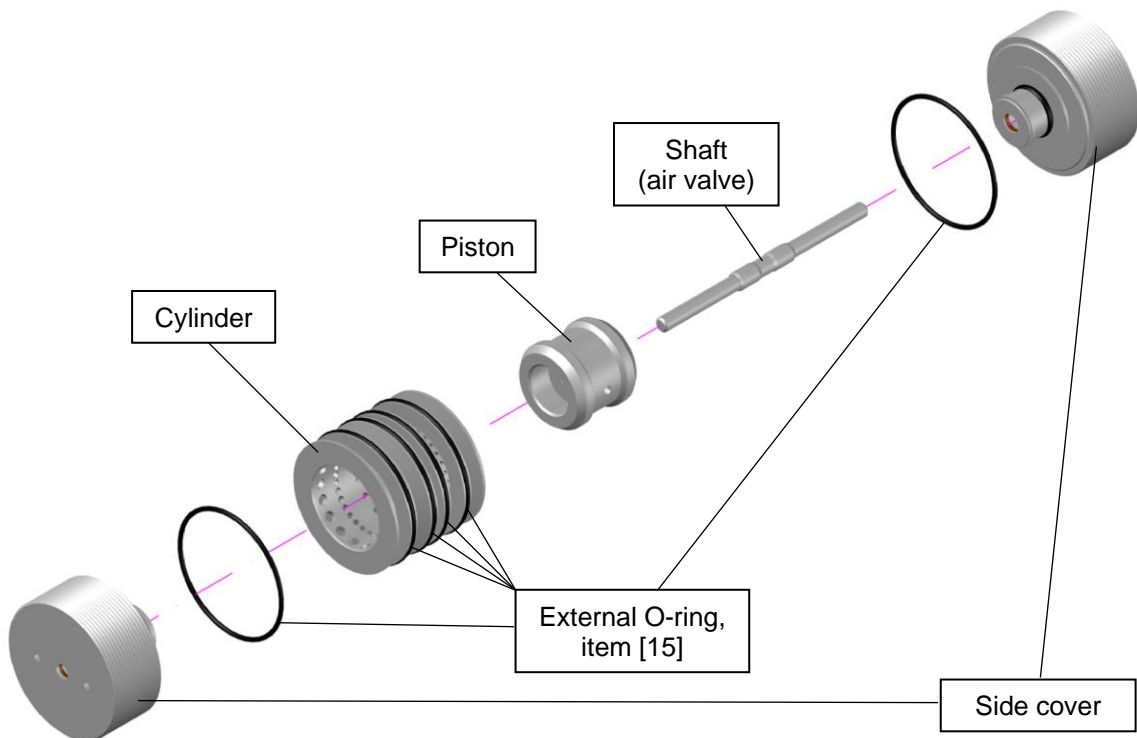

CAUTION: All the air valves stated above are thread-mounted type (actual version) – this type of assembling is available from August 2007. Before that date, air valves were assembled inside the central housing by means of circlip. Main difference between the both types of assembling are presented on the below picture:

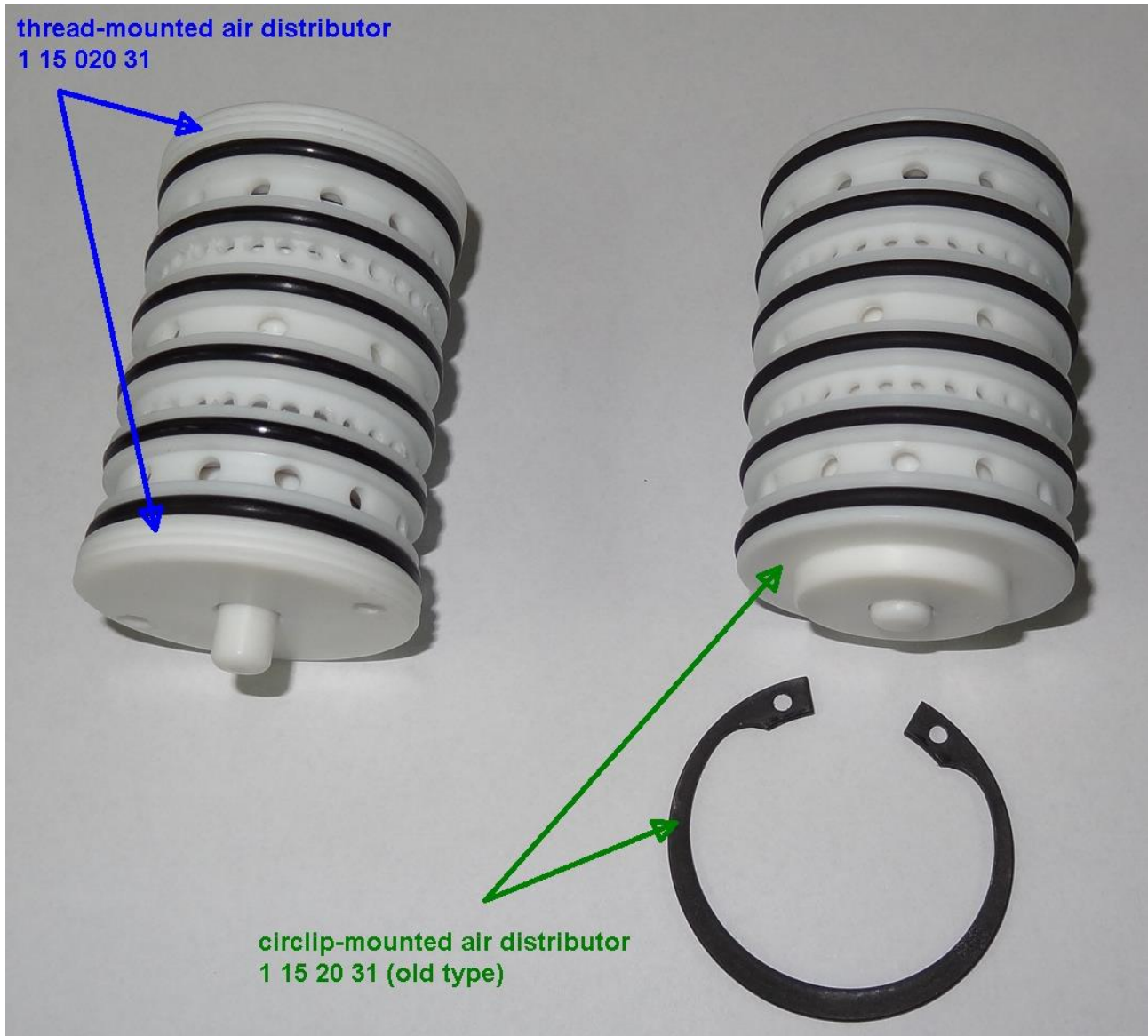

Before placing an order for an air valve, please check the pump's serial number and/or the required air valve's appearance, then send this information to DELLMECO Office or to our Authorized Distributor' Office (in order to avoid receiving of an incorrect part).

For the Plastic Series Pumps the following combinations of the main parts/O-ring execution materials can be offered:

- 1) AISI 316L/FKM (main parts – cylinder, piston, side covers – made from AISI 316L, the external O-rings are made from FKM) – for the sizes from DM 15/55 up to DM 50/565 size (air valves: “15” and “40” sizes).
- 2) Brass/EPDM (main parts – cylinder, piston, side covers – made from brass, the external O-rings are made from EPDM) – for the sizes from DM 08/10 up to DM 50/565 size (air valves: “08”, “15” and “40” sizes).
- 3) Brass/FKM (main parts – cylinder, piston, side covers – made from brass, the external O-rings are made from FKM) – for the sizes from DM 08/10 up to DM 50/565 size (air valves: “08”, “15” and “40” sizes).

The above material executions are not available for “80” air valve sizes (Pump size DM 80/850).

Not always an air valve unit has to be replaced completely – in some cases, air valve may require replacement of all internal slides and O-rings only (these parts are getting wear during normal operation of the pump) – this is why we also offer DELLMECO Air Valve Spare Part Kit Set (**AVD”xx”**, where “XX” stands for the size of the air valve). Depending on the air valve size and material execution (also for the slides and O-rings), the following sets are available:

- AVD01F ("08" size air valve with FKM O-rings);
- AVD01N ("08" size air valve with NBR O-rings);
- AVD02F ("15" size air valve with FKM O-rings);
- AVD02N ("15" size air valve with NBR O-rings);
- AVD03F ("40" size air valve with FKM O-rings);
- AVD03N ("40" size air valve with NBR O-rings);
- AVD04F ("80" size air valve with FKM O-rings);
- AVD04N ("80" size air valve with NBR O-rings).

16.17. Actual version of the exhaust muffler (comparison with the previous execution)

All the DELLMECO Pumps supplied with compressed air have an exhaust muffler – its purpose is to decrease the noise caused by the de-compressed air coming out from the exhaust channel, which is situated in the central housing – on the opposite side of the pump's compressed air inlet (air supply connection). Exhaust muffler is installed in the central housing by means of threaded connection. The connecting thread has been modified in 2018, but this amendment – implemented on both muffler and central housing – has been applied gradually (previous type of exhaust mufflers were still used, until their stocks were used up – however, old type mufflers are still available as spare parts). Difference between the actual and previously used type of thread is presented on the below picture (it applies to exhaust muffler sizes: "08", "10", "15", "40" and "50"), on the example of size "15" exhaust muffler (dedicated to pump models: DM 15/55.. and DM 25/125 ...):



Exhaust muffler with coarse thread,
part no.: 1 15 499 35 (actual version)

Exhaust muffler with fine thread,
part no.: 1 15 99 35 (previous version)

CAUTION: Exhaust muffler's previous version cannot be used as a spare part in an actual version of the central housing and vice-versa (both versions of thread are not interchangeable). To avoid any mistakes in the future, please always ask your customer about the pump's serial number and a picture of the actually used muffler or, at least, about a picture of the actually used muffler which has to be replaced. This also refers to SET1 and/or SET2 spare part kit sets, where the exhaust muffler is always included (all AODD Pump models). We DO NOT take responsibility for any mistaken muffler type ordered without prior coordinating with DELLMECO, or its Authorized Distributor.

Available execution material for the exhaust mufflers:

- PE porous (standard version of pumps and also for ATEX purpose)
- Sintered bronze (for standard version of pumps and/or for ATEX purpose – on demand).

16.18. A change in the manner of assembling/disassembling way of valve seats (available only for Plastic Series Pump models: from DM 10/25 to DM 50/565)

Date of introduction:
October 2022 (DM 25/125 Pump size)
January 2023 (DM 10/25, DM 15/55, DM 40/315, DM 50/565 Pump sizes)

Due to constant improvement of our products, we have implemented a modification in the way of assembling and/or disassembling of valve seats in the following sizes of the AODD Plastic Series Pumps:

- 1) DM 10/25 P., R., T., Z..
- 2) DM 15/55 P., R., T., Z..
- 3) DM 25/125 P., R., T., Z..
- 4) DM 40/315 P., R., T., Z..
- 5) DM 50/565 P., R., T., Z..

The solution being utilized before the change was the flat metal key [Item 97] with specially prepared notches for assembling and/or disassembling upper and lower valve seat [Item 22] – as on the below picture [Pict. 1]:

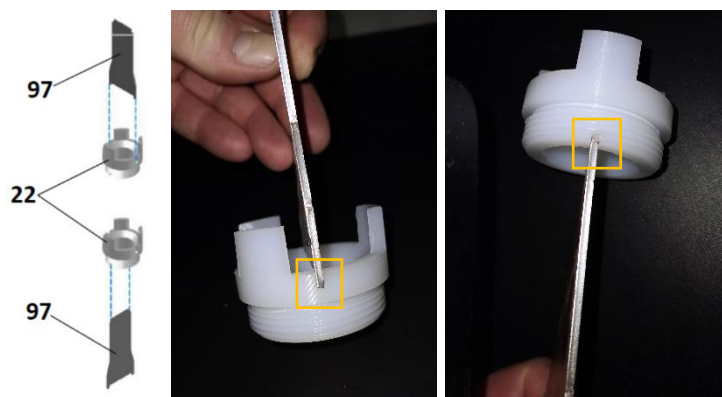

Pict. 1 – Upper/lower valve seat [Item 22] with valve key [Item 97] before the modification (notches are marked with yellow color).

Comparison of valve seats before and after modification is shown on the below picture [Pict. 2]:

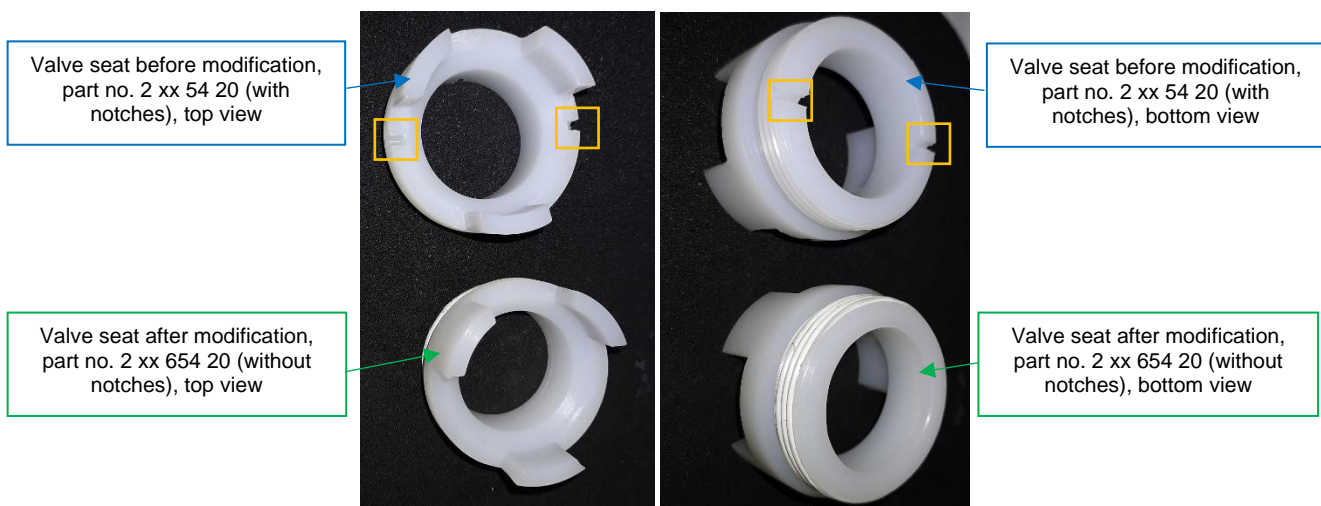

Pict. 2 – Upper/lower valve seats before modification (with valve key notches, top pictures) and after modification (no valve key notches, bottom pictures).

Modification consisted in changing a type of tool (for assembling and/or disassembling upper and lower valve seats, which are no longer equipped with notches on the upper and lower side) from the flat metal key (with specially prepared notches) into the plastic separated keys, which are machined in order to fit the valve seat's shape – as on the below pictures: [Pict. 3 – Upper valve key, Pict. 4 – Lower valve key with bar extension]:

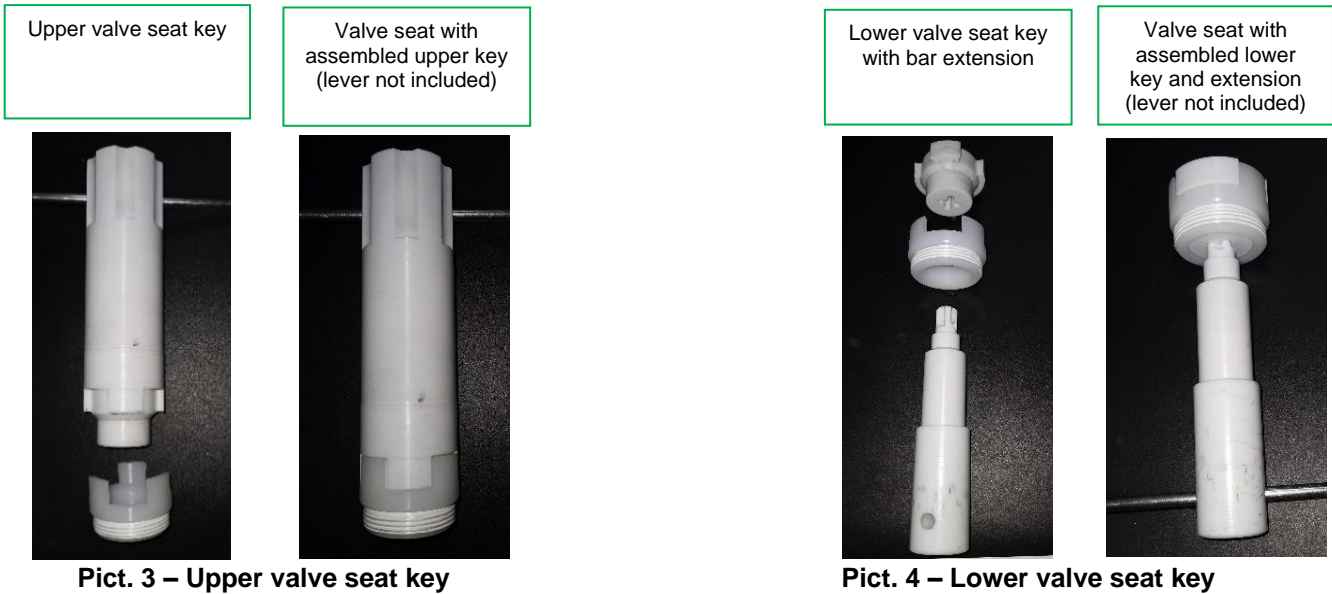

NOTE: Upper/lower valve key set do not contain steel lever.

SUMMARY:

This modification eliminates the possibility of damaging the notches with stainless steel key. In the case of damaged notches, worn valve seat will be hard to remove.
New type of key ensures higher torque and rigidity during disassembling process.

IMPORTANT: Old type of valve seats still can be assembled and/or disassembled by using new type of upper/lower valve seat keys.

Upper/lower valve keys of any size are not included in the scope of the purchased Plastic Series Pump and have to be ordered separately! For example:

Purchased AODD pump model: *DM 25/125 P.. (or R., T., Z. models)*

Required upper/lower valve seat key – part no.: 2 25 254C 00, q-ty: 1 set (includes upper and lower valve keys)

The above keys also fit for EODD pump models *DME 25 R.. and DME 25 Z...*

Purchased AODD pump model: *DM 40/315 P.. (or R., T., Z. models)*

Required upper/lower valve seat key – part no.: 2 40 254C 00, q-ty: 1 set (includes upper and lower valve keys)

The above keys also fit for EODD pump models *DME 40 R.. and DME 40 Z...*

Purchased AODD pump model: *DM 50/565 P.. (or R., T., Z. models)*

Required upper/lower valve seat key – part no.: 2 50 254C 00, q-ty: 1 set (includes upper and lower valve keys)

The above keys also fit for EODD pump models *DME 50 R.. and DME 50 Z...*

Please verify the actual version of your valve seats and check if you have appropriate tools in order to perform assembling and/or disassembling process.

16.19. Central housing with Enhanced Air Valve (EAV Option)

DELLMECO Plastic Series Pumps from DM 25/125 to DM 50/565 can be additionally equipped with air valve reinforcement – two opposite stainless steel plates fixed to the central housing by means of mounting screws (4 pcs of screws for each mounting plate). In such case air valve is not thread-mounted – assembled steel plates ensure the proper fixing. This modification extends the service life of both air distributor and central housing in the case of heavy applications and high pressure conditions – it can be applied especially for the pumps with HP Option, without changing the pump's external dimensions. Standard pump can be also re-assembled into EAV Option, but a complete central housing (made from PE conductive material for EAV Option) with an air valve has to be replaced.

Central housing with Enhanced Air Valve (EAV Option) – exploded view with list of parts:

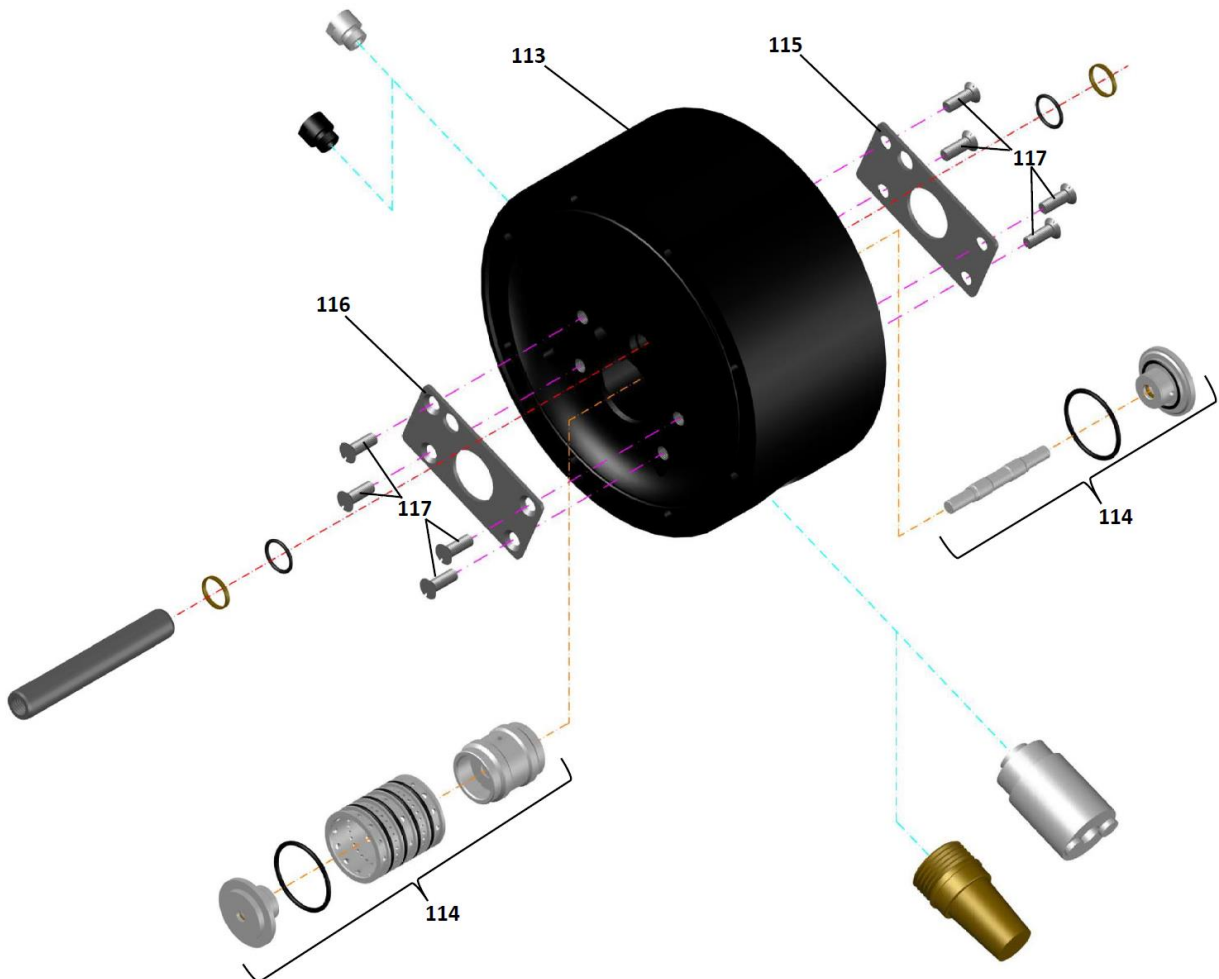

Spare part list for Enhanced Air Valve Option

					DM 25/125	DM 40/315	DM 50/565
Code	Position	Q-ty	Description	Material	Part no.	Part no.	Part no.
EAV	113.	1	Central housing for EAV Option (with Recoil inserts)	PE cond.	1 25 810 21	1 40 810 21	1 50 810 21
	114.	1	Air valve for EAV Option	PET/NBR	1 15 220 31	1 40 220 31	
				PET/FKM	1 15 220 32	1 40 220 32	
	115.	1	Air valve plate, left	AISI 304	1 25 764L 50	1 40 764L 50	1 50 764L 50
	116.	1	Air valve plate, right	AISI 304	1 25 764R 50	1 40 764R 50	1 50 764R 50
117.	2	Mounting screws set (per 1 plate)	AISI 304	1 25 744 50	1 40 744 50	1 50 744 50	

16.20. ATEX Certificate

DELLMECO Plastic Series Pumps manufactured from conductive PE or conductive PTFE can be adapted for installation and use in potentially explosive atmospheres. This feature ensures the pump can safely transfer inflammable solvents, alcohols and other volatile liquids without the danger of static electricity build-up (through grounding of non-metallic pumps). An appropriate combination of conductive materials makes DELLMECO Plastic Series Pumps suitable to work in explosive gas and dust environments without the risk of spark formation.

**Plastic Pump dedicated for ATEX
(PE cond. or PTFE cond. material)**



**Plastic Pump in standard execution – not for ATEX
(PE or PTFE material)**



Standard ATEX execution can be used for the following conditions:

CE Ex 2GD IIA/IIB T1÷T5

Optionally available is Plastic Series Pump to be used in ATEX “Zone 0” (on request only!):

CE 0408 Ex II 1/2 G Ex h IIB/IIC T4...T3 Ga/Gb PTB 18 ATEX 5008 X

or

CE 0408 Ex II 1G Ex h IIC T4...T3 Ga/Gb PTB 18 ATEX 5008 X

In order to obtain the additional information, please contact our customer support at: office@dellmeco.com .

17. Differences in construction of the air valve and special keys list

If you have any doubts when dismantling a pump, always refer to the mentioned procedures and safety notes from DELLMECO Manual for Plastic Pumps. Among the different sizes of DELLMECO Plastic series (from DM 15/55 to DM 80/850), only the number of housing bolts [9] varies. Besides, for the sizes DM 08/10 and DM 10/25, the diaphragm shaft [14] additionally functions as the pilot piston for the air distributor (air valve). In these pumps (DM 08/10 and DM 10/25), there are no central housing seals [16] and central housing O-rings [30]. Please keep these differences in construction in mind when reading the following dismantling instructions.

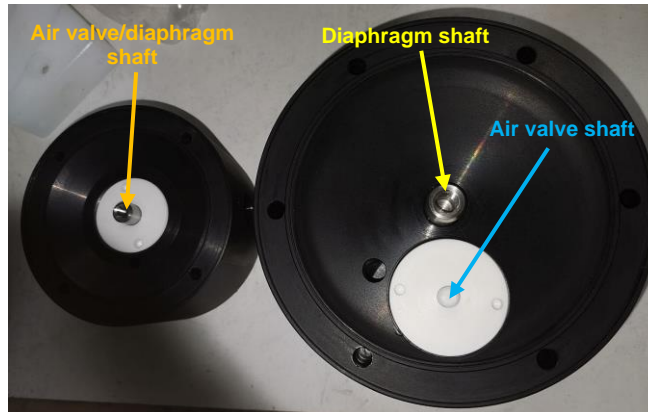

Comparison of two air valve types: DM 08/10 and DM 10/25 with common diaphragm/air valve shaft (left part) and from DM 15/55 to DM 80/850 – with separated air valve shaft (right part – air valve has its own shaft).

The general design of DELLMECO Plastic Series is quite simple. However, some special tools are required in order to assemble/disassemble specific pump's parts. Each of the special tools listed below is not delivered with pump and has to be ordered separately:

- 1) Universal adjustable key [100], with 2 pins (diameter of each pin is ca 4 mm):



This key can be used for air valve assembling/disassembling in all sizes of Plastic Series Pumps. It is also applicable for upper/lower plugs in Plastic Series Pumps starting from size DM 15/55.

NOTE: This universal key is not applicable for:

- upper/lower plugs in the Plastic Series Pump sizes DM 08/10;
- lower plugs in the Plastic Series Pump sizes DM 10/25.

- 2) Special air valve [13] assembling/disassembling key, available in four sizes:



Air valve size (part no.):	Special key part no.:
"08", "10" (1 08 020 31 and 1 08 020 32)	1 08 958 00
"15", "25" (1 15 020 31 and 1 15 020 32)	1 15 958 00
"40", "50" (1 40 020 31 and 1 40 020 32)	1 40 958 00
"80" (1 80 020 31 and 1 80 020 32)	1 80 958 00

NOTE: Stainless steel lever with cup nuts on each side is not a part of the key (not included).

- 3) Special wrenches for upper [25] and/or lower [24] plugs, designed for specific pump sizes (examples below):



NOTE: Stainless steel lever with cup nuts on each side is not a part of the key (not included).

Below chart shows part numbers for the specific type of upper/lower plug keys (the number of pins for each key is indicated in parentheses):

Pump size	Upper plug key part no.	Lower plug key part no.
08/10	1 08 158 00 (2 x 2 pins)	
10/25	1 10 158 00 (2 x 2 pins)	
15/55	1 15 758 00 (4 pins)	1 15 858 00 (2 pins)
25/125	1 25 758 00 (4 pins)	1 25 858 00 (2 pins)
40/315	1 40 758 00 (2 pins)	1 40 858 00 (2 pins)
50/565		1 50 858 00 (2 pins)
80/850	1 80 158 00 (2 x 2 pins)	

- 4) Metal valve seat key [97], for upper/lower valve seats with notches (!!!):



This special key is still applicable for the valve seats only in the below specified Plastic Series Pump sizes:

- DM 08/10
- DM 80/850

For the remaining sizes of Plastic Series Pumps – DM 10/25, DM 15/55, DM 25/125, DM 40/315 and DM 50/565 – this key is applicable only for the pumps equipped with not modified valve seats (old type, with notches).

NOTE: The change of valve seats to the new version began in October 2022. In order to verify the type of actually installed valve seats, please disassemble upper plug [25] in the Plastic Series Pump and make sure which type of valve seats are assembled (with metal valve seat key [97] disassembly and assembly of new type of valve seats – without notches – will not be possible!). We recommend to order new type of valve seat key – part number: 2 xx 254C 00 (“xx” stands for pump’s size: “10”, “15”, “25”, “40”, “50”).

For more information please refer to the **Chapter 16.19** (page 81 in this Manual).

- 5) Plastic valve seat key upper/lower [97a], for new type of upper/lower valve seats (without notches):

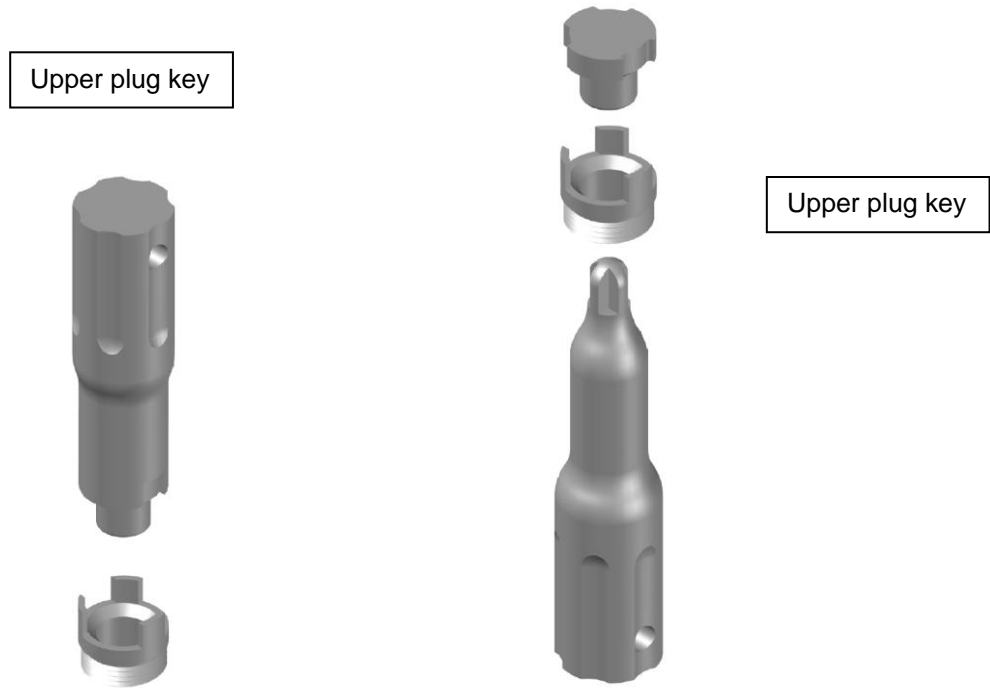

This special key is applicable for new type of valve seats (without notches) in the below specified Plastic Series Pump sizes (manufactured since October 2022):

- DM 10/25
- DM 15/55
- DM 25/125
- DM 40/315
- DM 50/565

Required upper/lower valve seat key – part no.: 2 xx 254C 00, q-ty: 1 set (includes upper and lower valve keys), where “xx” stands for the pump size (e.g., “10”, “15”, “25”, “40” or “50”).

Example: For the Plastic Series Pump model DM 25/125, required upper/lower valve seat key is: 2 25 254C 00.

NOTE: This valve seat key can be also applied to the previously used upper/lower valve seats (with notches). It also fits EODD pump models DME 25 R.. and DME 25 Z.. (with both old and/or new type of valve seats).

For more information, please refer to the **Chapter 16.18** (page 79 in this Manual).

18. Limited warranty

This product is shipped to customers only after meeting strict inspection standards. If an abnormality occurs during normal operation in accordance with the operating instructions and other operating cautions within the warranty period (24 months after date of purchase) that can be attributed to a manufacturing defect, the defective parts of this product will be serviced or the product will be replaced free of charge. However, this warranty will NOT cover compensation for incidental damage or any malfunction listed below.

1. Warranty period

This warranty is valid for 24 months after the date of purchase.

2. Warranty

If, during the warranty period, any of the material of the genuine parts of this product or the workmanship of this product is found defective, and is so verified by our company, the servicing cost will be fully covered by our company.

3. Exclusion

Even during the warranty period, this warranty DOES NOT cover the following:

- 1) Malfunction caused by the use of parts other than manufacturer-specified genuine parts.
- 2) Malfunction caused by misuse or operating errors, or lack of storage or maintenance care.
- 3) Malfunction caused by the use of a fluid that may cause corrosion, inflation or dissolution of the component parts of the product.
- 4) Irregularity caused by a repair made by other than our firm, our regional office, dealer or authorized service personnel.
- 5) Malfunction caused by a modification of the product by other than authorized service personnel.
- 6) Wear and tear of parts that must be regularly replaced in the course of normal operation, such as diaphragms, valve seats, balls, air motor sleeve valves and O-rings.
- 7) Malfunction and/or damage due to transportation, moving or droppage of the product after purchase.
- 8) Malfunction and/or damage due to fire, earthquake, flood or other force majeure.
- 9) Malfunction caused by the use of compressed air that contains impurities, air with oil or excessive moisture, or use of gases or fluids other than the specified compressed air.
- 10) Malfunction caused by the use of a fluid that causes excessive abrasion.

Furthermore, this warranty does not cover the rubber parts, or other parts that are subject to wear in normal operation, used in this product and its accessories.

4. Parts

Parts for this product will be kept available for 5 years after discontinuation of production. Once 5 years have elapsed after close of production, availability of parts for this product cannot be guaranteed.

Notes:

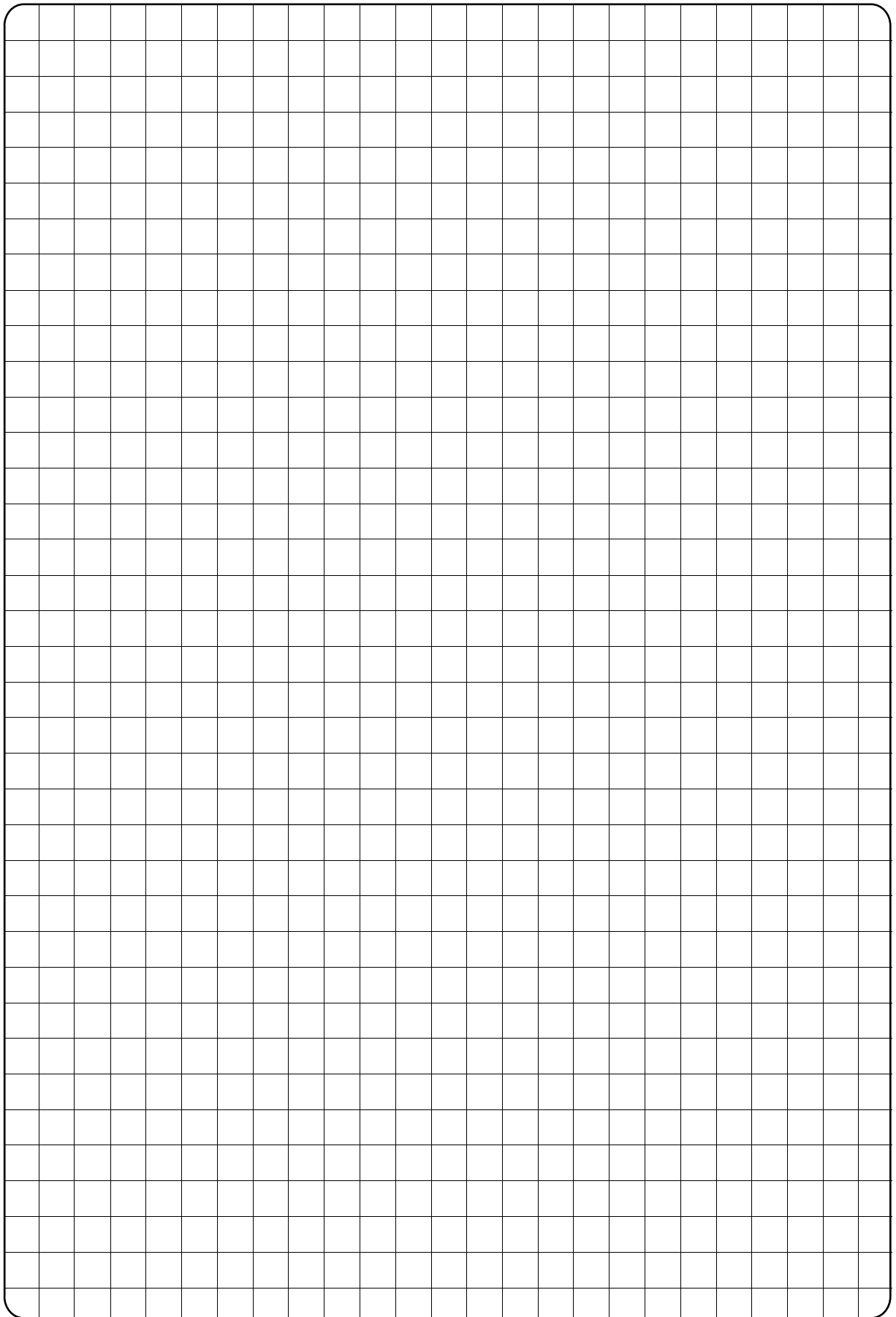

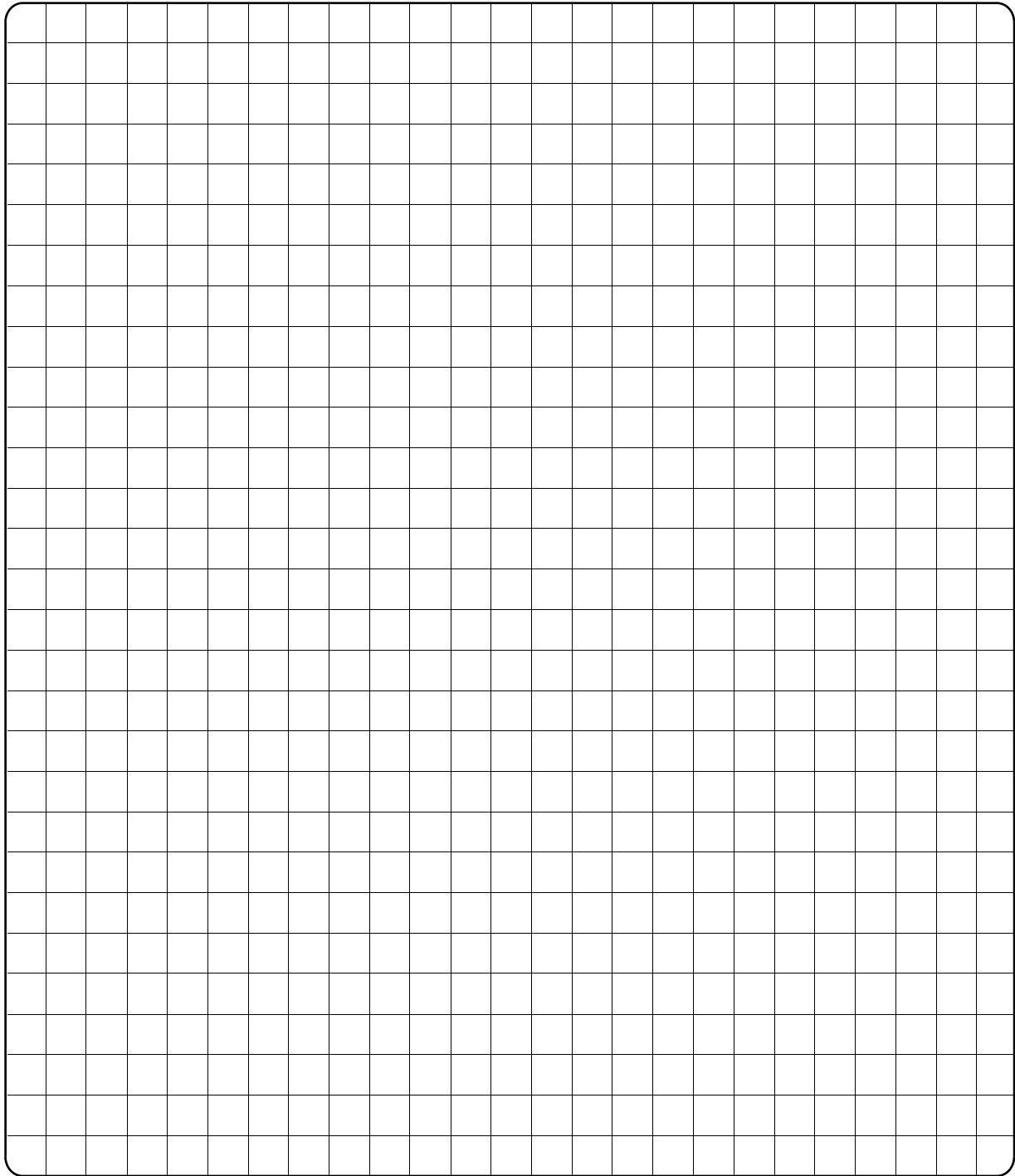

DELLMECO

Świerkowa 2
83-330 Glinz
POLAND
Tel.: +48 532 220 722

office@dellmeco.com
www.dellmeco.com

